

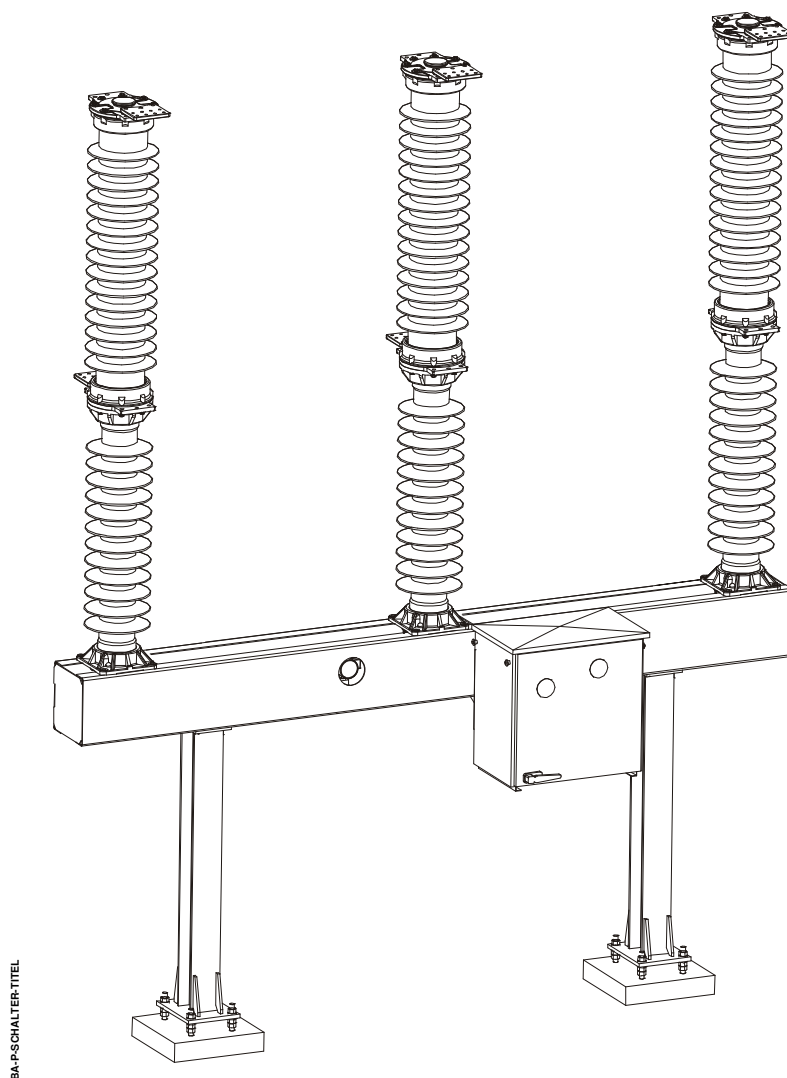

## Operating Instructions No. 246 (EN)

**Device:** High Voltage Circuit Breaker  
GL 310 F1/4031 P/VR      GL310 F1/4040 P/VR  
GL 311 F1/4031 P/VR      GL311 F1/4040 P/VR  
GL 312 F1/4031 P/VR      GL312 F1/4040 P/VR  
GL 313 F1/4031 P/VR



**Manufacturer: GE Grid GmbH**  
Lilienthalstrasse 150 - 34123 Kassel, Germany



<b>1</b>	<b>Introduction</b> .....	<b>7</b>
<b>2</b>	<b>Safety</b> .....	<b>11</b>
2.1	<i>Safety Instructions</i> .....	11
<b>3</b>	<b>Handling Sulfur Hexafluoride</b> .....	<b>13</b>
3.1	<i>Safety Precautions When Handling SF6</i> .....	13
3.1.1	<i>Oxygen Displacement</i> .....	13
3.1.2	<i>Mechanical Handling</i> .....	13
3.1.3	<i>Frostbite</i> .....	14
3.2	<i>Safety Precautions When Handling Used SF6</i> .....	15
3.3	<i>Transport at the Installation Site</i> .....	16
<b>4</b>	<b>Components Supplied</b> .....	<b>17</b>
4.1	<i>Scope of Supply (Standard)</i> .....	17
4.2	<i>Scope of Supply (Optional)</i> .....	18
<b>5</b>	<b>Transport and Storage</b> .....	<b>19</b>
5.1	<i>Transport and Handling</i> .....	19
5.2	<i>Storage</i> .....	20
<b>6</b>	<b>Installation</b> .....	<b>21</b>
6.1	<i>Preparing for Installation</i> .....	21
6.1.1	<i>Documentation</i> .....	21
6.1.2	<i>Checklist</i> .....	21
6.2	<i>Materials and Equipment to Be Provided by Customer</i> .....	24
6.3	<i>Use of Auxiliary Materials and Supplies</i> .....	24
6.4	<i>Unpacking the Transport Units</i> .....	24
6.4.1	<i>Base Frame</i> .....	25
6.4.2	<i>Pole Column</i> .....	25
6.4.2 a	<i>Unpacking Pole Column with Composite Insulators</i> .....	27
6.4.2 b	<i>Unpacking Pole Column with Porcelain Insulators</i> .....	28
6.4.3	<i>Operating Mechanism</i> .....	30
6.5	<i>Preinstalling the Supports</i> .....	31
6.6	<i>Installing the Base Frame</i> .....	32
6.7	<i>Installing the Mechanism Brackets</i> .....	33
6.8	<i>Mounting the Operating Mechanism</i> .....	34
6.9	<i>Installing the Pole Columns</i> .....	37
6.9.1	<i>Erecting the Pole Columns</i> .....	37
6.9.2	<i>Positioning the Pole Columns</i> .....	38
6.10	<i>Aligning and Connecting the Pole Columns</i> .....	40
6.11	<i>Aligning and Connecting Pole Column B</i> .....	41
6.11.1	<i>Connecting the Drive Rod to the Drive Lever</i> .....	42
6.11.2	<i>Connecting the Drive Rod to Pole B</i> .....	43
6.11.3	<i>Connecting the Lever to the Connecting Rod for Pole C</i> .....	45
6.11.4	<i>Aligning and Connecting Pole Column A</i> .....	46
6.11.5	<i>Aligning and Connecting Pole Column C</i> .....	47
6.12	<i>Mounting the High Voltage Terminal Pads</i> .....	48

## TABLE OF CONTENT

---

6.13	<i>Connecting the Cables</i> . . . . .	49
6.14	<i>Earthing (Grounding) the Circuit Breaker</i> . . . . .	50
<b>7</b>	<b>Commissioning</b> . . . . .	<b>51</b>
7.1	<i>Density Monitor</i> . . . . .	51
7.1.1	<i>Connecting the Cable</i> . . . . .	51
7.1.2	<i>Checking the Operating Points of the density monitor</i> . . . . .	52
7.2	<i>Filling the Pole Columns with Gas (Preparation)</i> . . . . .	54
7.2.1	<i>Establish Gas Connections between Density Monitor and Pole columns</i> . . . . .	55
7.3	<i>Filling the Breaker with Gas</i> . . . . .	56
7.4	<i>Checking the Anti-Condensation Heater</i> . . . . .	58
7.5	<i>Connecting the Supply and Control Cables</i> . . . . .	58
7.6	<i>Functional Testing</i> . . . . .	59
7.6.1	<i>Test Operations</i> . . . . .	59
7.6.2	<i>Measuring the Running Time of the Charging Motor</i> . . . . .	59
7.6.3	<i>Measuring the Contact Resistance</i> . . . . .	60
7.6.4	<i>Measuring the Operating Times</i> . . . . .	60
7.6.5	<i>Checking Manual Operation</i> . . . . .	61
7.6.6	<i>Manually Charging the Closing Spring</i> . . . . .	62
7.6.7	<i>Checking the Anti-Pumping System</i> . . . . .	63
7.6.8	<i>Checking the Functional Lockout</i> . . . . .	63
7.6.9	<i>Operations Counter</i> . . . . .	63
7.6.10	<i>Final Tasks</i> . . . . .	63
<b>8</b>	<b>Troubleshooting</b> . . . . .	<b>65</b>
8.1	<i>Electrical Switching Commands Are Not Correctly Executed</i> . . . . .	65
8.2	<i>Mechanism Reconditioning Procedures</i> . . . . .	66
8.2.1	<i>Replacing the Charging Motor</i> . . . . .	66
8.2.2	<i>Replacing the Closing and Opening Coil</i> . . . . .	67
8.2.3	<i>Replacing the Operations Counter</i> . . . . .	68
8.2.4	<i>Replacing the Motor Limit Switch and/or the Auxiliary Switch</i> . . . . .	69
8.3	<i>Replacing the Density Monitor</i> . . . . .	71
8.3.1	<i>Austausch einer Gasverbindung</i> . . . . .	73
<b>9</b>	<b>Inspection and Maintenance</b> . . . . .	<b>75</b>
9.1	<i>Ordering Accessories and Replacement Parts</i> . . . . .	77
9.2	<i>Inspection</i> . . . . .	77
9.2.1	<i>Visual Inspection</i> . . . . .	77
9.2.2	<i>Anti-Condensation Heater</i> . . . . .	77
9.2.3	<i>Checking Gas Pressure</i> . . . . .	77
9.3	<i>Maintenance</i> . . . . .	78
9.3.1	<i>Checking the Cable Connections</i> . . . . .	78
9.3.2	<i>Checking the Connecting Linkage</i> . . . . .	78
9.3.3	<i>Checking the Control Circuits</i> . . . . .	78
9.3.4	<i>Checking the Gas Quality</i> . . . . .	79
9.3.5	<i>Checking the Contact Resistance</i> . . . . .	79
9.3.6	<i>Checking the Operating Times</i> . . . . .	79
9.3.7	<i>Checking the Threaded Connections</i> . . . . .	79

<b>10</b>	<b>Reconditioning</b> .....	<b>81</b>
10.1	<i>Reconditioning the Interrupter Chamber</i> .....	82
10.1.1	<i>Disconnecting the Interrupter Chamber from the Post Insulator</i> .....	82
10.1.2	<i>Removing the Double Motion System</i> .....	84
10.1.3	<i>Removing the Guide Shaft</i> .....	85
10.1.3.1	<i>Switchgear with 4031</i> .....	85
10.1.3.2	<i>Switchgear with 4040</i> .....	86
10.1.4	<i>Disconnecting the Making and Breaking Units</i> .....	87
10.1.5	<i>Reconditioning the Movable Contact System</i> .....	87
10.1.6	<i>Reconditioning the Fixed Contact</i> .....	88
10.1.7	<i>Lubricating the Interrupter Unit</i> .....	88
10.1.8	<i>Connecting the Making and Breaking Units</i> .....	89
10.1.9	<i>Mounting the Guide Shaft</i> .....	91
10.1.9.1	<i>Switchgear with 4031</i> .....	91
10.1.9.2	<i>Switchgear with 4040</i> .....	92
10.1.10	<i>Reconditioning the Holder</i> .....	93
10.1.11	<i>Installing the Double Motion System</i> .....	94
10.1.12	<i>Adjusting the Double Motion System</i> .....	96
10.1.13	<i>Connecting the Interrupter Chamber to the Post Insulator</i> .....	97
10.1.14	<i>Replacing the Adsorption filter</i> .....	99
10.1.15	<i>Final Operations</i> .....	100
10.2	<i>Disassembling the Post Insulator and Crankcase</i> .....	100
10.2.1	<i>Disassembling the Opening Springs</i> .....	101
10.2.2	<i>Disassembling the Crankcase</i> .....	102
<b>11</b>	<b>End-of-Life Management</b> .....	<b>105</b>
<b>12</b>	<b>Special Equipment (Optional)</b> .....	<b>107</b>
12.1	<i>EasyCheck Density Monitor Unit</i> .....	107
12.1.1	<i>Functional description</i> .....	108
12.1.2	<i>Operating condition</i> .....	109
12.1.3	<i>Test condition</i> .....	110
12.2	<i>FlexLink-Gas Connection</i> .....	111
12.2.1	<i>Setup of the FlexLink-Gas Connction</i> .....	111
12.2.2	<i>If FlexLink Gas Piping Is Already Installed</i> .....	112
12.2.3	<i>FlexLink Gas Piping Still Needs To Be Installed</i> .....	113
12.2.4	<i>Exchange of FlexLink Gas Connections</i> .....	114
<b>A1</b>	<b>Description of the Equipment</b> .....	<b>117</b>
A1.1	<i>Purpose</i> .....	117
A1.2	<i>Main Components</i> .....	117
A1.3	<i>Operation</i> .....	117
<b>A2</b>	<b>Tools and Auxiliary Equipment</b> .....	<b>119</b>
A2.1	<i>Customer-Supplied Materials and Equipment for Installation and Commissioning</i> .....	119
A2.2	<i>Materials</i> .....	119
A2.3	<i>Hoisting and Climbing or Lifting Equipment</i> .....	119

## TABLE OF CONTENT

---

A2.4	<i>Tools, Test Equipment and Auxiliary Equipment</i> . . . . .	119
A2.4.1	<i>Tool Recommendations</i> . . . . .	120
A2.5	<i>Greases for Installation, Commissioning and Maintenance</i> . . . . .	123
A2.6	<i>Locking Adhesives for Installation, Commissioning and Maintenance</i> . . . . .	124
A2.7	<i>Measuring Devices for Checking Gas Quality</i> . . . . .	124
A2.8	<i>Tools for Reconditioning</i> . . . . .	125
A2.9	<i>Auxiliary Materials and Supplies</i> . . . . .	126
<b>A3</b>	<b>Replacement Parts and Accessories</b> . . . . .	<b>127</b>
A3.1	<i>Servicing Equipment</i> . . . . .	128
A3.2	<i>Replacement of Arcing Contacts</i> . . . . .	129
A3.3	<i>Replacement Parts for Installation Work on Post Insulator and Crankcase</i> . . . . .	129
<b>A4</b>	<b>Handling Used Sulfur Hexafluoride</b> . . . . .	<b>131</b>
<b>A5</b>	<b>Technical Description</b> . . . . .	<b>133</b>
A5.1	<i>Technical Data: Circuit Breaker Type GL 310-GL 311</i> . . . . .	133
A5.2	<i>Technical Data: Circuit Breaker Type GL 312 - GL 313</i> . . . . .	134
A5.3	<i>Technical Data: Spring Operating Mechanism</i> . . . . .	135
<b>A6</b>	<b>Slow Operation for Maintenance Purposes</b> . . . . .	<b>137</b>

## **1 Introduction**

Your decision to use GE high voltage switchgear means that you have chosen a product that is very advanced technically and has proven effective and reliable in the field.

The entire development and production process for our high voltage switchgear is controlled by a DIN ISO 9001 certified quality management system, an ISO 14001 certified environmental management system, and the OHSAS 18001 occupational health and safety management system. Regular audits guarantee that our products and services meet a high quality standard.

In order to ensure optimum operation (and take advantage of all product benefits), please follow the instructions in this manual when installing, commissioning and operating the equipment. In the event of problems or equipment malfunction, please contact your local GE representative.

This manual describes installation, commissioning, operation, inspection, maintenance and reconditioning. Additional copies of this manual can be obtained from your local GE representative by specifying the OI-number.

GE's high voltage switchgear units are specifically designed to allow for long maintenance intervals. The operational reliability of the equipment is guaranteed by proper servicing and by following the instructions given in this manual. GE assumes no liability for damage due to failure to follow the manual instructions.

This document and the equipment described herein are subject to change without notice in the interest of further development. No claims of any kind may be derived from the specifications, figures or descriptions.

**GE Grid GmbH**  
**Lilienthalstrasse 150**  
**34123 Kassel**  
**Germany**  
**Telephone: +49 561 502-0**  
**Fax: +49 561 502-2499**

### **Copyright Notice**

©2016 General Electric Company. All rights reserved.

The information contained in this publication is the exclusive property of General Electric Company, except as otherwise indicated. You may view, copy and print documents and graphics incorporated in this publication (the "Documents") subject to the following: (1) the Documents may be used solely for personal, informational, non-commercial purposes; (2) the Documents may not be modified or altered in any way; and (3) General Electric Company withholds permission for making the Documents or any portion thereof accessible via the internet. Except as expressly provided herein, you may not use, copy, print, display, reproduce, publish, license, post, transmit or distribute the Documents in whole or in part without the prior written permission of General Electric Company.

### **Trademark Notices**

GE and GE Logo are trademarks and service marks of General Electric Company.

IEC is a registered trademark of Commission Electrotechnique Internationale.

IEEE and POSIX are registered trademarks of the Institute of Electrical and Electronics Engineers, Inc.

Any further company and product names mentioned in this publication may be trademarks or registered trademarks of the respective companies.



BG	Това оборудване съдържа флуориран парников газ (SF <sub>6</sub> ), обхванат в Протокола от Киото, който има потенциал за глобално затопляне (ПГЗ) 22200. SF <sub>6</sub> трябва да се улавя, а не да се изпуска в атмосферата. Повече информация относно използването и боравенето с SF <sub>6</sub> ще намерите в IEC 62271: High-Voltage Switchgear and Controlgear - Part 4: Use and Handling of Sulphur Hexafluoride (SF <sub>6</sub> ).
CS	Toto zařízení obsahuje fluorový skleníkový plyn (SF <sub>6</sub> ), na který se vztahuje Kjótský protokol a který má potenciál ke globálnímu oteplování (GWP) 22200. SF <sub>6</sub> je třeba zpětně získat - nesmí se vypouštět do ovzduší. Více informací o použití a manipulaci s SF <sub>6</sub> viz IEC 62271: High-Voltage Switchgear and Controlgear - Part 4: Use and Handling of Sulphur Hexafluoride (SF <sub>6</sub> ).
DA	Denne udstyr indeholder fluoreret drivhusgas (SF <sub>6</sub> ), omfattet af Kyoto-protokollen, som har et globalt opvarmningspotentiale (GWP) på 22200. SF <sub>6</sub> skal anvendes i et hermetisk lukket system og må ikke udlædes i atmosfæren. For yderligere oplysninger om anvendelse og håndtering af SF <sub>6</sub> , henvises til IEC 62271: High-Voltage Switchgear and Controlgear - Part 4: Use and Handling of Sulphur Hexafluoride (SF <sub>6</sub> ).
DE	Das Betriebsmittel enthält das vom Kyoto-Protokoll erfasste fluorierte Treibhausgas SF <sub>6</sub> mit einem Treibhauspotenzial (GWP) von 22200. SF <sub>6</sub> muss zurückgewonnen werden und darf nicht in die Atmosphäre entlassen werden. Bei dem Umgang und der Handhabung mit SF <sub>6</sub> sind die Vorgaben in IEC 62271 High-Voltage Switchgear and Controlgear - Part 4 Use and Handling of Sulphur Hexafluoride (SF <sub>6</sub> ) zu beachten.
EL	Αυτός ο εξοπλισμός περιέχει φθοριούχο αέριο θερμοκηπίου (SF <sub>6</sub> ) που καλύπτεται από το Πρωτόκολλο του Κιότο και έχει Δυναμικό Θέρμανσης του πλανήτη (GWP) 22200. Το SF <sub>6</sub> θα πρέπει να περισυλλέγεται και να μην απελευθερώνεται στην ατμόσφαιρα. Για περισσότερες πληροφορίες σχετικά με τη χρήση και το χειρισμό του SF <sub>6</sub> , ανατρέξτε στο IEC 62271: High-Voltage Switchgear and Controlgear - Part 4: Use and Handling of Sulphur Hexafluoride (SF <sub>6</sub> ).
EN	This equipment contains Fluorinated Greenhouse Gas (SF <sub>6</sub> ) covered by the Kyoto Protocol, which has a Global Warming Potential (GWP) of 22200. SF <sub>6</sub> should be recovered and not released into the atmosphere. For further information on the use and handling of SF <sub>6</sub> , please refer to IEC 62271: High-Voltage Switchgear and Controlgear - Part 4: Use and Handling of Sulphur Hexafluoride (SF <sub>6</sub> ).
ES	Este equipo contiene Gas Fluorado de efecto invernadero (SF <sub>6</sub> ) contemplado en el Protocolo de Kyoto, cuyo potencial de calentamiento global es de 22200 GWP. El SF <sub>6</sub> debe ser recuperado y no emitido a la atmósfera. Para más información del uso y gestión del SF <sub>6</sub> , por favor ponerse en contacto con IEC 62271: High-Voltage Switchgear and Controlgear - Part 4: Use and Handling of Sulphur Hexafluoride (SF <sub>6</sub> ).
ET	Käesolev seade sisaldab Kyoto protokolliga hõlmatud fluoritud kasvuhoonegaase (SF <sub>6</sub> ), millel on suur globaalne soojenemise potentsiaal (GWP) – 22200. SF <sub>6</sub> tuleks kokku koguda ning seda ei tohi atmosfääri lasta. Rohkem teavet SF <sub>6</sub> kasutamise ja käitlemise kohta vaadake IEC 62271: High-Voltage Switchgear and Controlgear - Part 4: Use and Handling of Sulphur Hexafluoride (SF <sub>6</sub> ).
FI	Laitte sisältää Kioton pöytäkirjassa mainittua fluorattua kasvihuonekaasua (SF <sub>6</sub> ) jonka globaali lämmityspotentiaali (GWP) on 22200 kertainen hiilidioksiidin GWP arvoon verrattuna. SF <sub>6</sub> kaasua ei saa päästää ilmakehään, vaan se on kerättävä asianmukaisesti talteen. Lisätietoja SF <sub>6</sub> kaasun käytöstä ja käsittelystä löytyy IEC 62271: High-Voltage Switchgear and Controlgear - Part 4: Use and Handling of Sulphur Hexafluoride (SF <sub>6</sub> ).
FR	Cet équipement contient un gaz à effet de serre fluoré (SF <sub>6</sub> ) couvert par le protocole de Kyoto qui a un Pouvoir de Réchauffement Global de 22200 (PRG). Le SF <sub>6</sub> doit être récupéré et ne doit pas être relâché dans l'atmosphère. Pour plus d'information sur l'utilisation et la manipulation du SF <sub>6</sub> vous pouvez vous référer à la norme CEI 62271 : Appareillage haute tension - Partie 4 : Utilisation et manipulation de l'Hexafluorure de soufre (SF <sub>6</sub> ).
GA	Tá Gás Ceaptha Teasa Fluairínithe (SF <sub>6</sub> ), le Poitéinseal Téimh Domhanda (PTD) de 22200, a thagann faoin bPrótacal Kyoto, sa treatlamh seo. Ba chóir SF <sub>6</sub> a aisghabháil agus ní cóir é a scaoileadh amach san atmaisféar. Chun breis faisnéise a rochtain ar conas SF <sub>6</sub> a úsáid agus a láimhseáil, déan tagairt le do thoil le IEC 62271: High-Voltage Switchgear and Controlgear - Part 4: Use and Handling of Sulphur Hexafluoride (SF <sub>6</sub> ).
HU	A berendezés kén hexafluorid gázt (SF <sub>6</sub> ) tartalmaz a Kyoto szabályozásnak megfelelően, amelynek hatása van a 22200 föld felmelegítési képességére (GWP). Az SF <sub>6</sub> gázt vissza kell nyerni, és nem az atmoszférába kell engedni. Az SF <sub>6</sub> gázra vonatkozó kezeléssel kapcsolatos további információért lásd IEC 62271: High-Voltage Switchgear and Controlgear - Part 4: Use and Handling of Sulphur Hexafluoride (SF <sub>6</sub> ).
IT	Questa apparecchiatura contiene Esafloruro di Zolfo (SF <sub>6</sub> ), disciplinato dal protocollo di Kyoto, che ha un Potenziale di Riscaldamento Globale (GWP) di 22200. Il gas SF <sub>6</sub> dovrebbe essere recuperato e non rilasciato nell'atmosfera. Per ulteriori informazioni sull'uso e la movimentazione del gas SF <sub>6</sub> , per favore rivolgersi a IEC 62271: High-Voltage Switchgear and Controlgear - Part 4: Use and Handling of Sulphur Hexafluoride (SF <sub>6</sub> ).
LT	Šis aprikojums satur Kioto protokolā ietvertu fluorinēto siltumnīcu gāzi (SF <sub>6</sub> ), kam piemīt globālās sasilšanas potenciāls (GWP) 22200. SF <sub>6</sub> ir jāatjauno un to nedrīkst izlaist atmosfērā. Papildinformāciju par SF <sub>6</sub> izmantošanu un aprādi, lūdzu, skatiet IEC 62271: High-Voltage Switchgear and Controlgear - Part 4: Use and Handling of Sulphur Hexafluoride (SF <sub>6</sub> ).
LV	Šis ierangs sudētyje yra šiltnamio efekta sudarančių fluorintų dujų (SF <sub>6</sub> ), kurioms taikomas Kioto protokolas ir kurių globalinio klimato atšilimo potencialas („Global Warming Potential“, GWP) yra 22200. SF <sub>6</sub> neturi būti išgaunamos ir išleidžiamos į atmosferą. Daugiau informacijos apie SF <sub>6</sub> naudojimą ir tvarkymą ieškokite IEC 62271: High-Voltage Switchgear and Controlgear - Part 4: Use and Handling of Sulphur Hexafluoride (SF <sub>6</sub> ).
MT	Dan it-tagħmir jinkludi l-Fluorinated Greenhouse Gas (SF <sub>6</sub> ) koprut mill-Protokoll ta' K'joto, li għandu Potenzial ta' Tishin tad-Dinja (Global Warming Potential) (GWP) ta' 22200. SF <sub>6</sub> għandu jinġabar lura u mhux jinheles fl-atmosfera. Għal aktar informazzjoni dwar l-użu l-gestjoni ta-SF <sub>6</sub> , jekk jogħġbok irreferi għal IEC 62271: High-Voltage Switchgear and Controlgear - Part 4: Use and Handling of Sulphur Hexafluoride (SF <sub>6</sub> ).
NL	Dit product bevat Gefluoreerd Broeikasgas (SF <sub>6</sub> ) dat is opgenomen in het Protocol van Kyoto. Dit gas heeft een aardopwarmingspotentieel (GWP) van 22200. SF <sub>6</sub> moet worden opgeslagen en mag niet in de atmosfeer terecht komen. Voor meer informatie over het gebruik en de behandeling van SF <sub>6</sub> verwijzen wij u naar IEC 62271: High-Voltage Switchgear and Controlgear - Part 4: Use and Handling of Sulphur Hexafluoride (SF <sub>6</sub> ).
PL	To urządzenie zawiera sześćciofluorek siarki (SF <sub>6</sub> ), fluorowany gaz cieplarniany objęty Protokołem z Kioto, którego potencjał tworzenia efektu cieplarnianego (Global Warming Potential - GWP) wynosi 22200. SF <sub>6</sub> powinien być odzyskiwany i nie uwalniany do atmosfery. Po dalsze informacje na temat użycia i obsługi SF <sub>6</sub> , proszę zwracać się do IEC 62271: High-Voltage Switchgear and Controlgear - Part 4: Use and Handling of Sulphur Hexafluoride (SF <sub>6</sub> ).
PT	Este equipamento contém gás hexafluoreto de enxofre (SF <sub>6</sub> ), o qual faz parte do Protocolo de Kyoto por possuir um Efeito Estufa de 22200. O gás SF <sub>6</sub> deve ser recuperado, não podendo ser lançado diretamente para a atmosfera. Para maiores informações sobre o uso e manuseio de gás SF <sub>6</sub> , por favor consultar o IEC 62271: High-Voltage Switchgear and Controlgear - Part 4: Use and Handling of Sulphur Hexafluoride (SF <sub>6</sub> ).
RO	Acest echipament conține gaz fluorurat cu efect de seră (SF <sub>6</sub> ), reglementat de Protocolul de la Kyoto, cu un potențial de încălzire globală de 22200. SF <sub>6</sub> trebuie recuperat, nu eliberat în atmosferă. Pentru mai multe informații privind utilizarea și manipularea gazului SF <sub>6</sub> , consultați IEC 62271: High-Voltage Switchgear and Controlgear - Part 4: Use and Handling of Sulphur Hexafluoride (SF <sub>6</sub> ).
SK	Toto zariadenie obsahuje fluorované skleníkové plyny (SF <sub>6</sub> ), ktoré podliehajú Kjótskému protokolu, a ktoré majú potenciál globálneho otepľovania (GWP) rovný 22200. SF <sub>6</sub> by mali byť recyklované a nie vypúšťané do atmosféry. Ak potrebujete ďalšie informácie ohľadom použitia a manipulácie s SF <sub>6</sub> , obráťte sa na IEC 62271: High-Voltage Switchgear and Controlgear - Part 4: Use and Handling of Sulphur Hexafluoride (SF <sub>6</sub> ).
SL	Ta oprema vsebuje fluoriran toplogredni plin (SF <sub>6</sub> ), na katerega se nanaša Kjotski protokol, in ima potencial globalnega segrevanja (GWP) 22200. SF <sub>6</sub> se mora izločiti in shraniti in se ga ne sme izpuščati v ozračje. Več informacij o uporabi in rokovanju s SF <sub>6</sub> , boste našli v IEC 62271: High-Voltage Switchgear and Controlgear - Part 4: Use and Handling of Sulphur Hexafluoride (SF <sub>6</sub> ).
SV	Denna utrustning innehåller fluoriserad växthusgas (SF <sub>6</sub> ) vilken innefattas i Kyoto-protokollet och har en Global Warming-potential (GWP) om 22200. SF <sub>6</sub> bör återvinnas och ej avges till atmosfären. För ytterligare information om användning och hantering av SF <sub>6</sub> , se IEC 62271: High-Voltage Switchgear and Controlgear - Part 4: Use and Handling of Sulphur Hexafluoride (SF <sub>6</sub> ).
HR	Radna tvar sadrži fluorirani stakleni?ki plin sumporov heksafluorid (SF <sub>6</sub> ) koji je obuhva?en Kjotskim protokolom i ?iji stakleni?ki potencijal (potencijal globalnog zagrijavanja - GWP) iznosi 22200. SF <sub>6</sub> mora se oporabiti i ne smije se ispuštati u atmosferu. Prilikom uporabe i rukovanja plinom SF <sub>6</sub> potrebno je pridržavati se odredbi norme IEC 62271 - Visokonaponska sklopna aparatura, 4. dio - Uporaba i rukovanje sumpornim heksafluoridom (SF <sub>6</sub> ).



## 2 Safety

### 2.1 Safety Instructions

The operator of the high voltage switchgear described in this manual must make sure

- that work on high voltage switchgear is carried out solely by qualified personnel;
- that work complies with electrical codes and standards;
- that the individuals assigned to do the work are familiar with this manual and the safety instructions in the manual and that these instructions are followed.

Personnel can obtain the necessary qualifications for operating the equipment by completing appropriate training programs at GE.

The five safety rules of electrical engineering must be followed:

- Disconnect the equipment from the power supply.
- Install safeguards to ensure that the power cannot be turned on again.
- Confirm that the equipment is de-energized.
- Earth (ground) and short-circuit the equipment.
- Cover or provide barriers for adjacent energized equipment.

This manual contains specific safety alert symbols and signal words that are defined as follows:



Dangerous situation that will result in death or serious injury.



Dangerous situation that could result in death or serious injury.



Dangerous situation that could result in minor or moderate injury.



Situation that could result in damage to the product and/or a nearby object.

---



### **3 Handling Sulfur Hexafluoride**

Sulfur hexafluoride (SF<sub>6</sub>) is an inert gas that is colorless and odorless, chemically neutral, non-combustible and approximately five times heavier than air. It is non-toxic and is not an ozone-depleting substance.

Pure SF<sub>6</sub> is completely safe for human beings and animals physiologically. Because of its weight, however, it can displace the air in poorly ventilated, lower-lying or underground spaces (e.g. basements, cable ducts and maintenance shafts).

SF<sub>6</sub> is not classified as a hazardous substance in European chemicals legislation.

It has no ecotoxic potential and does not contribute to destruction of the ozone layer. Because of its high global warming potential (22,200), it can contribute to the greenhouse effect if it is released into the atmosphere. Therefore do not dump or otherwise discharge SF<sub>6</sub> to the atmosphere, and reduce incidental emissions wherever possible.

If SF<sub>6</sub> is used to fill electrical switchgear, it must comply with standard IEC 60376.

#### **Standards governing SF<sub>6</sub> handling**

- IEC 60480 Guidelines for the checking and treatment of sulfur hexafluoride taken from electrical equipment and specification for its re-use.
- IEC 62271-4 Use and handling of sulphur hexafluoride (SF<sub>6</sub>) in high-voltage switchgear and controlgear.

#### **3.1 Safety Precautions When Handling SF<sub>6</sub>**

##### **3.1.1 Oxygen Displacement**

SF<sub>6</sub> is five times heavier than air and can accumulate in underground rooms or poorly ventilated spaces if it gets into the work environment in large quantities. In such cases air is displaced, which consequently reduces the amount of oxygen available. If the oxygen concentration drops below 16% (IEC 62271-4), there is the danger that personnel working in the surrounding area will suffocate. Poorly ventilated or non-ventilated underground spaces such as basements, cable ducts, maintenance shafts and drainage systems are especially vulnerable.

##### **3.1.2 Mechanical Handling**

The SF<sub>6</sub> operating pressure in the switchgear unit is higher than the atmospheric air pressure. To avoid the danger of injury resulting from mechanical breakage of housing components, personnel must comply with the safety precautions specified in the appropriate chapters of this operating manual.

### 3.1.3 Frostbite

If compressed SF<sub>6</sub> escapes quickly, the sudden expansion lowers its temperature. The gas temperature can drop substantially below 0°C. A person accidentally exposed to a gas jet may suffer severe frostbite. Therefore always wear safety goggles, leather gloves and appropriate work clothes when carrying out procedures involving components filled with SF<sub>6</sub>.



- Do not eat, drink, smoke or store food in rooms containing SF<sub>6</sub> systems or equipment.
  - Make sure there is good room ventilation when servicing SF<sub>6</sub> switchgear (evacuating, filling, opening or cleaning the units).
  - When carrying out procedures involving SF<sub>6</sub>-filled components, always wear safety goggles, leather gloves and appropriate work clothes in order to prevent frostbite resulting from accidentally released gas.
-

### 3.2 Safety Precautions When Handling Used SF<sub>6</sub>

SF<sub>6</sub> gas used in electrical equipment may contain decomposition products with toxic properties if it has been subjected to arcs. These decomposition products may exist in either a gaseous state or in the form of a powder.

Even small amounts of gaseous decomposition products give off warning signals (such as unpleasant pungent odors or irritation of nose, mouth and eyes), which allow people to escape in time to a safe location. Decomposition products in powder form irritate the skin.



- Do not eat, drink, smoke or store food in rooms containing SF<sub>6</sub> systems or equipment.
- Make sure there is good room ventilation when servicing SF<sub>6</sub> switchgear (evacuating, filling, opening or cleaning the units).
- When carrying out procedures involving SF<sub>6</sub>-filled components, always wear safety goggles, leather gloves and appropriate work clothes in order to prevent frostbite resulting from accidentally released gas.
- Do not stir up powdery decomposition products.
- Remove powdery decomposition products using an industrial vacuum cleaner equipped with a filter. The industrial vacuum cleaner must comply at a minimum with the specifications for dust class L (light).
- Avoid skin contact with, swallowing or inhaling powdery decomposition products by complying with the following rules:
  - Wear appropriate protective respiratory equipment such as a full-face respirator (gas mask) or a respirator and gas-tight safety goggles.
  - Wear a dustproof protective suit (disposable suit).
  - Wear rubber gloves or disposable gloves.
  - Wear rubber boots or disposable boots.
  - After work is completed, wash the respirator, safety goggles and rubber gloves with water. Collect the water and dispose of it separately.
  - After work is completed, wash your entire body thoroughly with soap and plenty of water.

---

Contaminated materials such as

- solid decomposition products,
- used drying agents,
- vacuum cleaner bags containing powdery decomposition products,
- or disposable protective clothing

must be neutralized and disposed of in accordance with the guidelines defined in IEC 62271-4 and local regulations.

## HANDLING SULFUR HEXAFLUORIDE

---

### 3.3 Transport at the Installation Site

---



All pressure specifications are given in terms of relative pressure ( $p_e$ ).

---

Pole columns are shipped at a gas gauge pressure of approximately 0.03 MPa ( $p_e$ ) (0.3 bar).

---



The bursting of pressurized parts such as insulators or bushings may result in property damage or personal injury.

**Therefore:**

- **Do not move pole columns if the gas gauge pressure is higher than the shipping pressure.**
-



## 4 Components Supplied

### 4.1 Scope of Supply (Standard)

The shipment for each circuit breaker includes the following components:

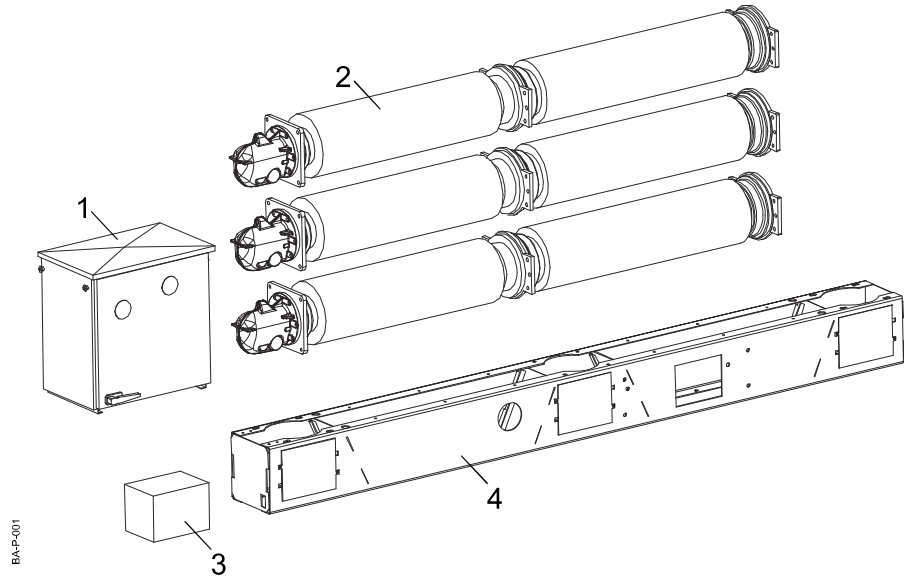

1	Operating mechanism	1x
2	Pole column	3x
3	Crate containing accessories	1x
4	Base frame	1x

# COMPONENTS SUPPLIED

## 4.2 Scope of Supply (Optional)

Neither the supports nor the gas for the circuit breaker are included in the scope of supply. If desired, these components can be ordered separately.

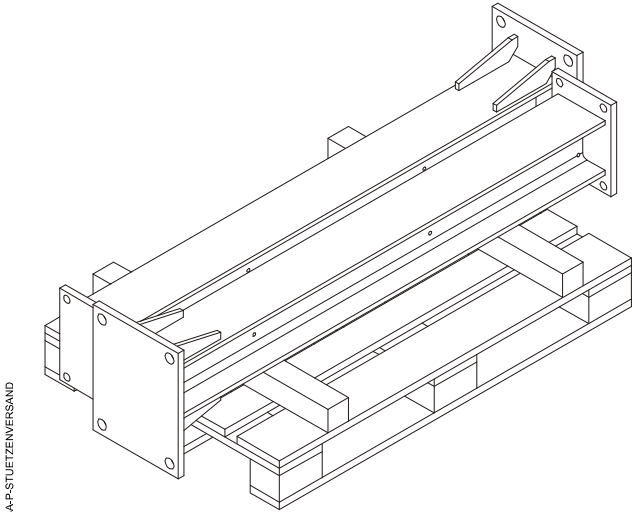

Support

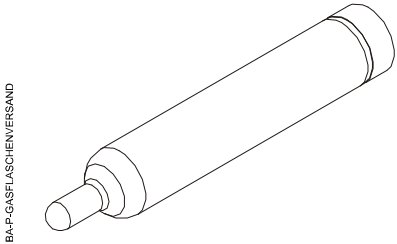

Gas cylinder

5 Transport and Storage

5.1 Transport and Handling













Improper handling of the transport units may result in serious damage.

Therefore:

- Comply with handling markings and labeling.
- Use hoisting equipment with adequate load-bearing capacity.
- Do not stand under suspended loads.

The transport units are provided with handling markings and labeling. The type and number varies according to the type of transport unit. The handling markings give information about the safe handling of the transport units and must always be followed.

	Fragile		This way up
	Sling here		Center of gravity
	Use no forks		Use forks
	Stacking limit by weight		Do not stack
	Keep dry		Clamp indicated as
	Do not damage barrier layer		

## TRANSPORT AND STORAGE

---

The wood used for the packaging may be chemically or thermally treated in order to prevent the spread of wood pests. Related rules and markings are defined in U.N. International Plant Protection Convention (IPPC) guidelines.

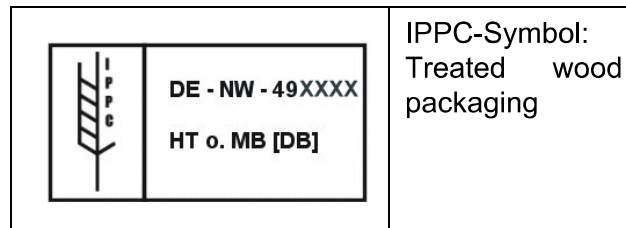

### 5.2 Storage

The transport unit packaging is only designed for a limited storage period.

The following periods, figured from the shipping date, shall apply to storage in transport packaging:

- Storage outdoors: four months maximum
- Storage in a dry room: six months maximum.

The following periods and conditions shall apply to storage after unpacking:

- Storage outdoors: unlimited. The operating mechanism must be in the mounting position, and the anti-condensation heating unit must be connected and in operation.
- Storage in a dry room: unlimited.

---

<b>CAUTION</b>
----------------

Depending on the transport conditions, the operating mechanism may be wrapped and sealed in sheet or foil. This prevents penetration of moisture.

If the sheet or foil is damaged, the operating mechanism must be stored as described above.

---

## **6 Installation**

### **6.1 Preparing for Installation**

#### **6.1.1 Documentation**

The following documents are required for installation and commissioning and must be available at the installation site:

- Shipping documents
- Instruction manual with accompanying checklist
- Dimensioned drawing of the circuit breaker
- Schematic diagram of the circuit breaker
- Routine test certificate for the circuit breaker

#### **6.1.2 Checklist**

The checklist is an essential supporting document for installation and commissioning and is enclosed with this manual as a colored sheet.

Performance of individual operations or steps must be confirmed on the checklist. For some operations, measured values must also be recorded.

A separate checklist must be filled out for each breaker, and after commissioning it must be completed by filling in the date, name of authorized individual, company stamp and signature (clearly legible). A copy must be sent to the following address, indicating the serial no. of the circuit breaker in the subject:

GE Grid GmbH  
Service Germany  
Lilienthalstrasse 150  
34123 Kassel  
Germany  
Hotline: +49 1803 257866  
Fax: +49 561 502-2774  
E-Mail: [checkliste.kassel@alstom.com](mailto:checkliste.kassel@alstom.com)

---

The checklist is part of the warranty agreement between the customer and GE Grid GmbH. In the event of a warranty claim, the warranty claim may be reduced or declined if the completed checklist is not on file at GE Grid GmbH.

---

## INSTALLATION

### Checklist for Installation and Commissioning

Circuit Breaker Data			
Type & Serial No.:			
Customer:			
Station:			
Installation			
No.	Operation to Be Performed	Section	✓
1	Safety instructions have been carefully read and are understood	2.1	
2	Materials provided by station checked for completeness	A2	
3	Shipment checked for completeness and lack of damage	6.4	
4	SF <sub>6</sub> shipping pressure in each pole column checked	6.4.2	
5	Component serial numbers checked for agreement	6.6	
6	Base frame and supports aligned	6.6	
7	Base frame connected to supports	6.6	
8	Supports tightened to final torque	6.6	
9	Mechanism brackets installed	6.7	
10	Operating mechanism mounted	6.8	
11	Pole columns installed	6.9	
12	Pole column B aligned and connected	6.11	
13	Drive rod connected to drive lever	6.11.1	
14	Drive rod connected to Pole B	6.11.2	
15	Lever connected to connecting rod for Pole C	6.11.3	
16	Pole column A aligned and connected	6.11.4	
17	Pole column C aligned and connected	6.11.5	
18	Transport lock removed from operating mechanism	6.8	
19	High voltage terminal pads mounted	6.12	
20	Base frame and supports earthed (grounded)	6.14	

**Checklist for Installation and Commissioning**

<b>Circuit Breaker Data</b>			
<b>Type &amp; Serial No.:</b>			
<b>Customer:</b>			
<b>Station:</b>			
<b>Commissioning:</b>			
No.	Operation to Be Performed	Section	✓ or Value
1	Safety instructions have been carefully read and are understood	2.1	
2	Safety instructions for SF <sub>6</sub> handling have been carefully read and are understood	3	
3	Density monitor electrically connected	7.1.1	
4	Operating points of density monitor checked	7.1.2	
5	Pole columns inspected visually	7.2	
6	SF <sub>6</sub> piping connected to the pole columns	7.2	
7	SF <sub>6</sub> gas topped up to rated pressure as shown on nameplate	7.3	
8	SF <sub>6</sub> piping seals checked using SF <sub>6</sub> leak detector	7.3	
9	Resistance of anti-condensation heater checked [in ohms]	7.4	
10	Supply and control cables connected	7.5	
11	Five closing and five opening operations executed by remote control	7.6.1	
12	Running time of charging motor measured	7.6.2	s
13	Contact resistance measured (> 100A DC)	7.6.3	μΩ
14	Closing time [ms] checked	7.6.4	A ms B ms C ms
15	Opening time [ms] checked	7.6.4	A ms B ms C ms
16	Manual closing & opening operations checked	7.6.5	
17	Anti-pumping system checked	7.6.7	
18	Functional lockout checked	7.6.8	
19	Count shown on operations counter recorded	7.6.9	
20	Testing and measuring equipment removed	7.6.10	

Please send one completed and signed copy of the checklist to:  
 GE Grid GmbH, Service Germany, Lilienthalstrasse 150, 34123 Kassel, Germany  
**Fax: +49 561 502-2774, E-Mail: [checkliste.kassel@alstom.com](mailto:checkliste.kassel@alstom.com)**

---

Place Date Stamp Signature

### 6.2 Materials and Equipment to Be Provided by Customer

Materials and equipment not included in the scope of supply are listed in the appendix. They include the following items:

- Tools
- Hoisting equipment
- Testing and measuring equipment
- Materials
- Foundations, anchor bolts and fasteners
- Supports
- Gas for filling the circuit breaker

These materials and equipment must be provided by the station.

### 6.3 Use of Auxiliary Materials and Supplies

Auxiliary materials and supplies needed for installation are shipped in the box containing accessories.

Detailed instructions for use of required auxiliary materials and supplies such as lubricants and locking compounds are given in Appendix A2. The various procedures are indicated in the text of the instruction manual by abbreviations (such as L1 or S1), which are explained in the appendix.

### 6.4 Unpacking the Transport Units

Check the transport units for completeness and lack of damage. In the event of shipping damage, notify the freight forwarder and your authorized GE representative immediately.



Improper handling of the transport units may result in serious damage.

**Therefore:**

- **Comply with handling markings and labeling.**
  - **Use hoisting equipment with adequate load-bearing capacity.**
  - **Do not stand under suspended loads.**
-



**6.4.1 Base Frame**

- Place two squared timbers on the ground as supports for the base frame.
- Fasten lifting tackle to the base frame using two M16 eyebolts. Use two holes located diagonally from one another in the center of the base frame for this purpose.
- Lift the base frame out of the packaging and lower it onto the squared timbers.

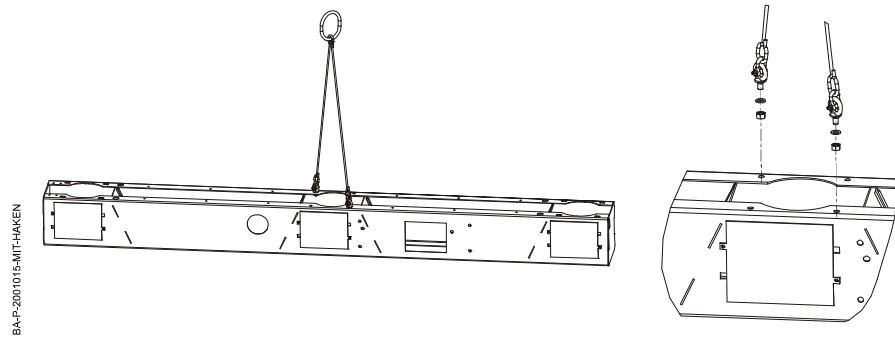

**6.4.2 Pole Column**

The pole columns can be equipped with two different types of insulators: **composite or porcelain insulators**. This means that they need to be handled differently.

The two types of insulators can be identified as follows:

**Composite insulators**

- Flexible sheds

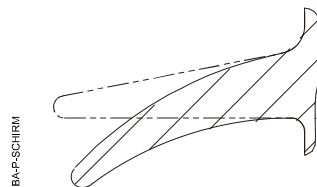

**CAUTION**

Oil and cleaning additives attack the silicone surface of the insulator.

**Therefore:**

- **Clean and wash the silicone shielding using only water or isopropyl alcohol.**

**Porcelain insulators**

- Rigid sheds

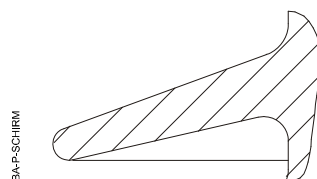



Due to damage that may have occurred during transport, a visual inspection of the insulators' condition is required before every initial filling and commissioning, as well as after maintenance work or any other actions.

**Therefore:**

- **all present persons must take cover or**
- **comply with the following minimum distance:**
  - for porcelain insulators: approx. 50 m**
  - for composite insulators: the height of the device****(measured from ground level to the upper edge device)**

The filling gas must be used purs. to IEC 60376.

---

6.4.2 a Unpacking Pole Column with Composite Insulators

**CAUTION**

Attaching lifting tackle to the silicone surface can damage the insulator.

Therefore:

- **Attach lifting tackle solely to the fastening points provided (on the lower post insulator flange and the upper terminal pad mounting plate).**

- Place two squared timbers on the ground as supports for the pole column. The pole column must be deposited on the lowermost and uppermost insulator flange, and the squared timbers must be spaced accordingly. The insulator sheds must not come in contact with the squared timbers or the ground, and the dimensions of the squared timbers must be selected accordingly.
- Attach slings and appropriate lifting accessories (shackle, eyebolt or lifting eye nut) to the lower flange of the post insulator and the upper terminal pad mounting plate.
- Lift the pole column out of the packaging and lower it on to the squared timbers.

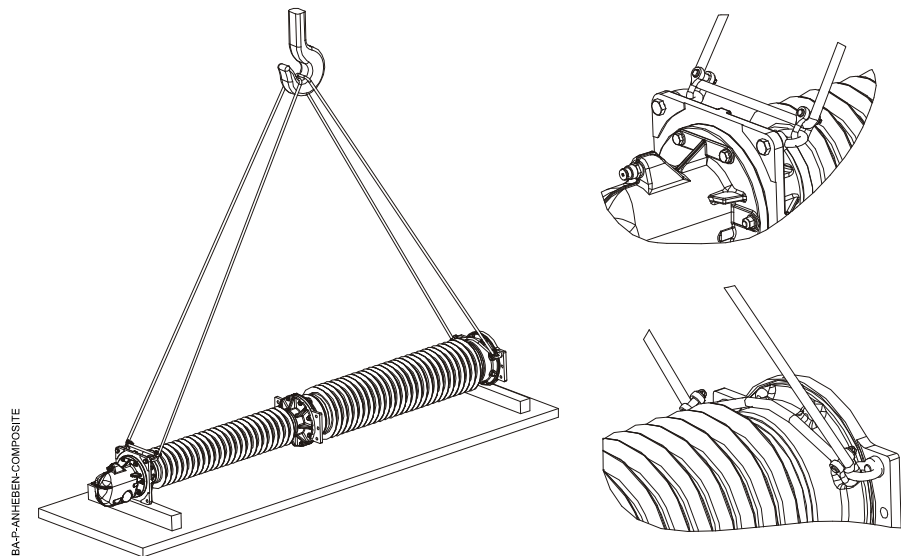

**CAUTION**

Contact with the ground may damage the insulators.

Therefore:

- **Select squared timbers of sufficient height, and position them correctly in order to prevent the insulators from touching the ground.**

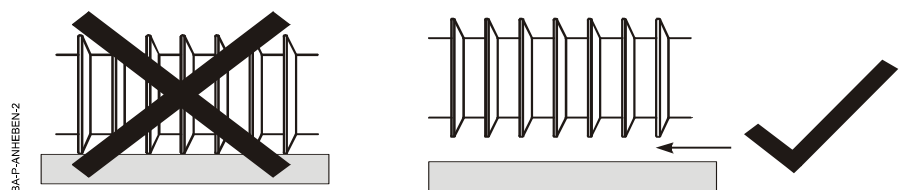

## 6.4.2 b Unpacking Pole Column with Porcelain Insulators

- Place two squared timbers on the ground as supports for the pole column. The pole column must be deposited on the lowermost and uppermost insulator flange, and the squared timbers must be spaced accordingly. The insulator sheds must not come in contact with the squared timbers or the ground, and the dimensions of the squared timbers must be selected accordingly.
- Loop a sling around the insulator below the sheds. Hook the other end of the sling in the crane hook.
- Loop a sling around the insulator above the sheds. Hook the other end of the sling in the crane hook.
- Lift the pole column out of the packaging and lower it on to the squared timbers.

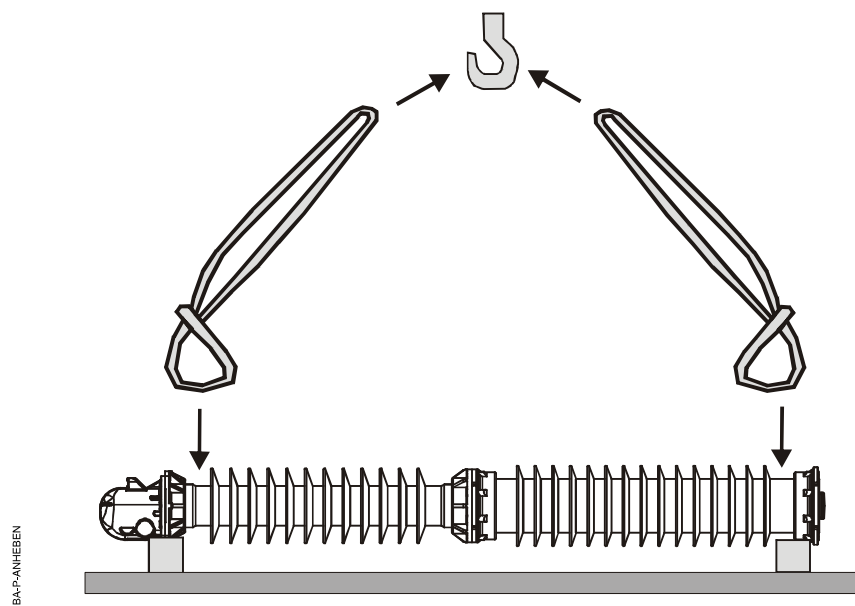

Contact with the ground may damage the insulators.

**Therefore:**

- **Select squared timbers of sufficient height, and position them correctly in order to prevent the insulators from touching the ground.**

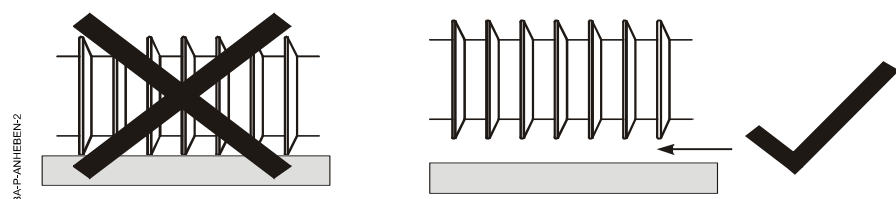

### Checking the SF<sub>6</sub> Shipping Pressure

The pole columns are filled with SF<sub>6</sub> at 0.3 bar for shipping purposes. This means that the pole columns do not need to be evacuated during commissioning. If a pole column is no longer at the correct shipping pressure upon installation, this may indicate shipping damage to the pole column.

We recommend that the shipping pressure indicator (T116) or another appropriate instrument be used to check the shipping pressure.



The indicator's maximum permissible gauge pressure is 1 bar. The indicator is intended solely for checking shipping pressure.

**Therefore:**

**Do not use the shipping pressure indicator to check rated pressures, alarm pressures or blocking pressures.**

---

### Procedure for using the shipping pressure indicator

- Unscrew the screw cap (2). This exposes the poppet valve (3) of the check valve.
- Place the shipping pressure indicator (T116) axially on the gas coupling (1) and press it briefly until it hits the mechanical stop. This opens the poppet valve (3) and transmits the pole column pressure to the shipping pressure indicator. The pressure indication remains visible until the next measurement due to a check valve in the shipping pressure indicator.
- Remove the shipping pressure indicator axially and evaluate the indication.
- Screw on the screw cap (2) again.

### Evaluating the indication

- The pointer should be in the green area of the scale.
- If the pointer is in the red area on the left, this indicates a lack of shipping pressure and therefore shipping damage.
- If the pointer is in the red area on the right, this indicates an overload on the shipping pressure indicator. In this case the shipping pressure indicator must be recalibrated.

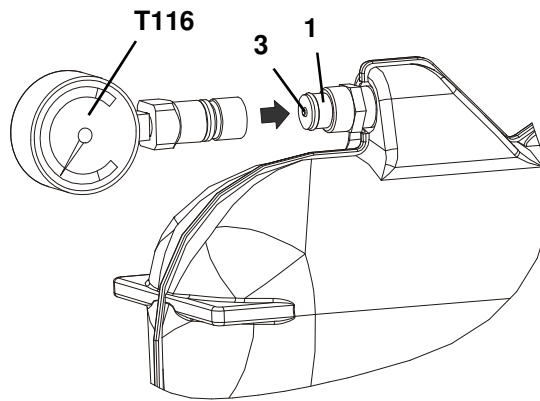
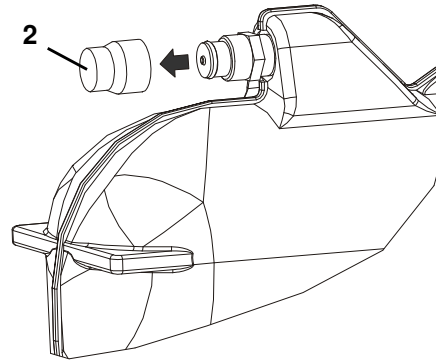

ba-ventilpiz

1	Gas coupling	-
2	Screw cap	-
3	Poppet valve	-

## 6.4.3 Operating Mechanism

Leave the operating mechanism in its packaging until you are ready to install it. Install the operating mechanism immediately after unpacking.

**6.5 Preinstalling the Supports**

Each support is fastened with four anchor bolts. Each anchor bolt has three nuts and two washers. The support is adjusted using the two lower nuts. The support is secured using the upper nut. One washer each is placed between the support and the nut immediately below and above it.

- Remove the upper nuts (2) and washers (3) from the anchor bolts.
- Screw the lower anchor bolt nuts (2) down until they are just above the foundation.
- Lubricate the anchor bolt threads as per L1.
- Fasten the lifting tackle (6) to the support (1) using two M16 eyebolts and two shackles. Use two holes located diagonally from one another in the top plate for this purpose.
- Lift the support and set it down on the four anchor bolts.
- Screw the upper washers (3) and nuts (2) on the anchor bolts until finger-tight. The nuts will be adjusted later during the alignment operations.
- Remove the lifting tackle (6).

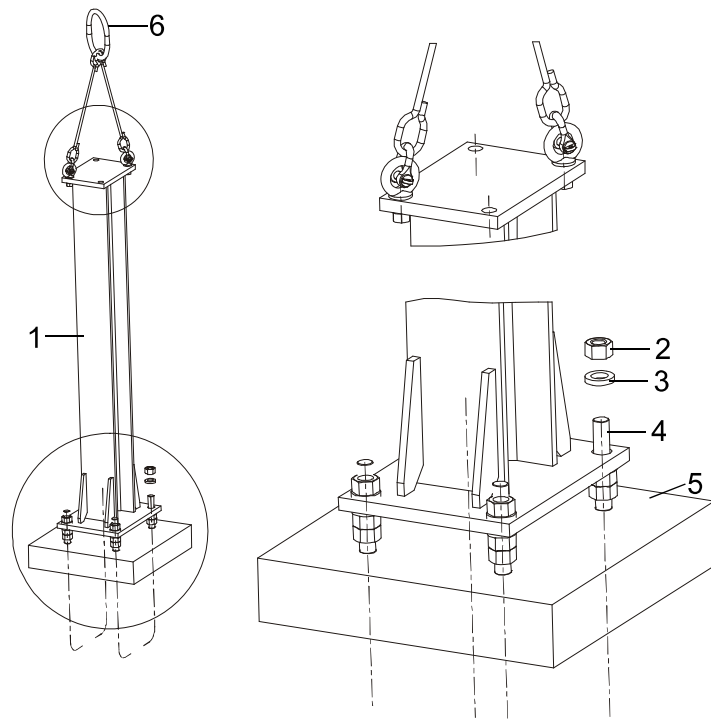

BA-P-TS-HEBEN

1	Support	1x
2	Nut, M24	12x
3	Washer, 24	8x
4	Anchor bolts	Provided at site by customer (corrosion-resistant steel with minimum strength of Rp 235 N/mm <sup>2</sup> )
5	Foundation	Provided at site by customer
6	Lifting tackle	-

## 6.6 Installing the Base Frame

- Check the base frame serial number, which is located on a sticker on the base frame itself.
- Check to make sure the serial number agrees with the breaker serial number.
- Remove the three cover plates (6) from the base frame.
- Remove the drive rods and connecting rods from the base frame.
- Attach the lifting tackle to the base frame (1) and position it above the supports (2).
- Set the base frame down on the supports, using the bolts (3) as a centering aid.
- Lubricate the bolts (3) as per L1.
- Preinstall the bolts (3), washers (4) and nuts (5) and tighten until finger-tight.
- Adjust the anchor bolt nuts (*see “Preinstalling the Supports” on Page 31*) until the upper ends of the supports are in direct contact with the underside of the base frame.
- Tighten the bolted joints connecting the supports to the base frame to a final torque of 286 Nm.
- Using a level, align the top of the base frame horizontally in both directions. Adjust the anchor bolt nuts to correct any misalignment. Always make adjustments via both supports in order to prevent deformation of the base frame.
- Tighten the anchor bolt nuts to a final torque of 250 Nm.

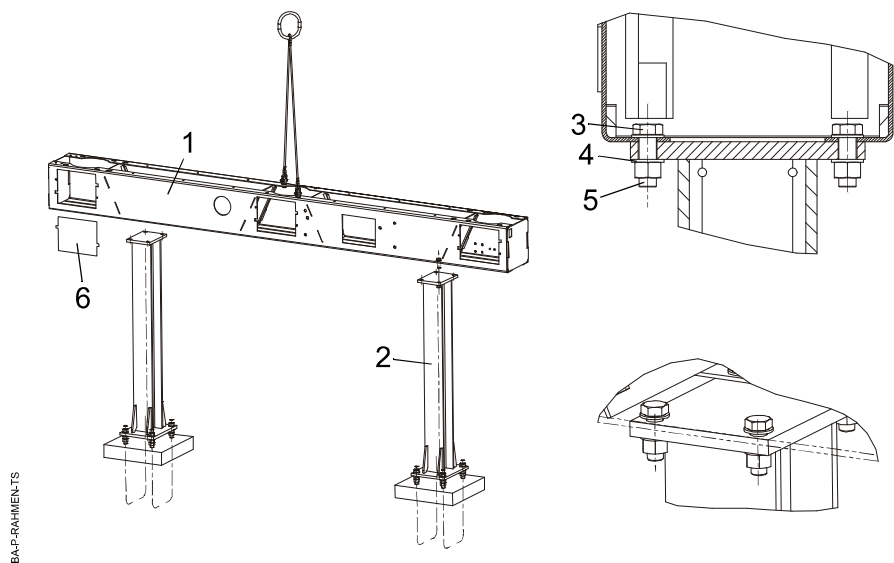

1	Base frame	1x
2	Support	2x
3	Hexagon bolt, M20x60 8.8 TZN	8x
4	Washer, 20 A2	16x
5	Hexagon nut, M20 A2-70	8x
6	Cover plate	3x



6.7 Installing the Mechanism Brackets

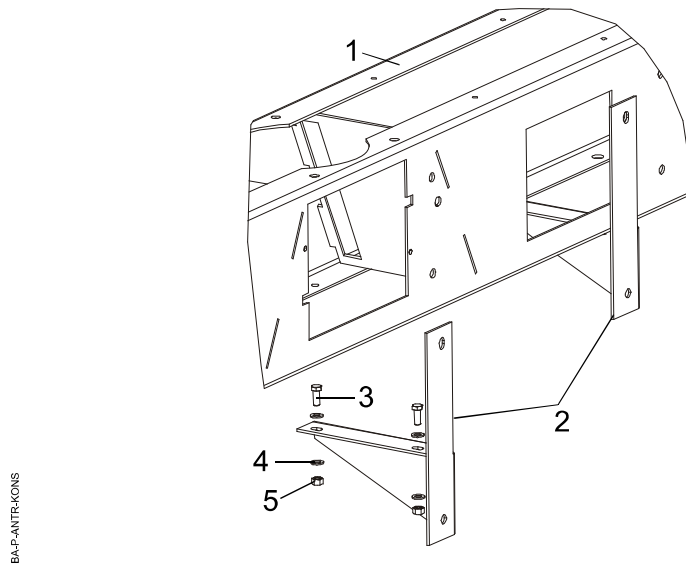

1	Base frame	1x
2	Mechanism bracket	2x
3	Hexagon bolt, M12x30 A2-70	4x
4	Washer, 12 A2	8x
5	Hexagon nut, M12 A2-70	4x

- Position the mechanism brackets (2) so that they are flush with the front and bottom of the base frame (1).
- Lubricate the bolts (3) as per L1.
- Align the holes in the mechanism brackets with the holes in the base frame, and bolt the brackets to the underside of the base frame in two places each. Tighten to a torque of 60 Nm.
- Check to make sure the mechanism brackets are correctly positioned and attached.

### 6.8 Mounting the Operating Mechanism

---

**CAUTION**

Operating the mechanism when it is not connected to the pole columns will destroy the operating mechanism.

**Therefore:**

- **Never operate the mechanism without the pole columns.**
- 

Place the operating mechanism on a suitable surface in front of the base frame.

- Check the serial number of the operating mechanism. The serial number is located on the nameplate on the outside of the door.
  - Check to make sure the serial number agrees with the breaker serial number.
- 

**DANGER**

Sudden movements of mechanism elements may lead to serious personal injury or property damage.

**Therefore:**

- **The operating mechanism must be completely discharged during installation.**

**The position indications must be as follows:**

**Closing spring indication: "Spring discharged"**

**Mechanism position: "OPEN" / "0"**

If this is not the case, do not trigger or operate the mechanism under any circumstance. GE Service must be notified.

---

The ingress of water (rain) must be prevented at all times. Therefore always protect the operating mechanism from rain during installation.

Remove the two side panels of the operating mechanism:

- Remove nuts (5) and tooth lock washers (4)
- Pull out the bottom of the side panel (2)
- Remove the side panel by pulling it downwards

Remove the roof (3) of the operating mechanism:

- Loosen the four bolts (6) on the roof
- Lift off the roof

Reverse the sequence to reinstall the roof and side panels after work is completed. Tighten the bolts (6) and nuts (5) to a torque of 17 Nm.

One mounting point in the mechanism is hidden by the spring guard plate. In order to mount the operating mechanism, proceed as follows:

- Loosen the two bolts (7) and remove the spring guard plate (8).

The opening latch of the operating mechanism may be immobilized by a transport lock. The transport lock consists of a cable tie with an attached identification card.

- Cut through the cable tie and remove the transport lock.

The bolts, washers and nuts for mounting the operating mechanism are preinstalled on the mechanism.

- Remove the mechanism fasteners - bolts, washers and nuts - from the mechanism.

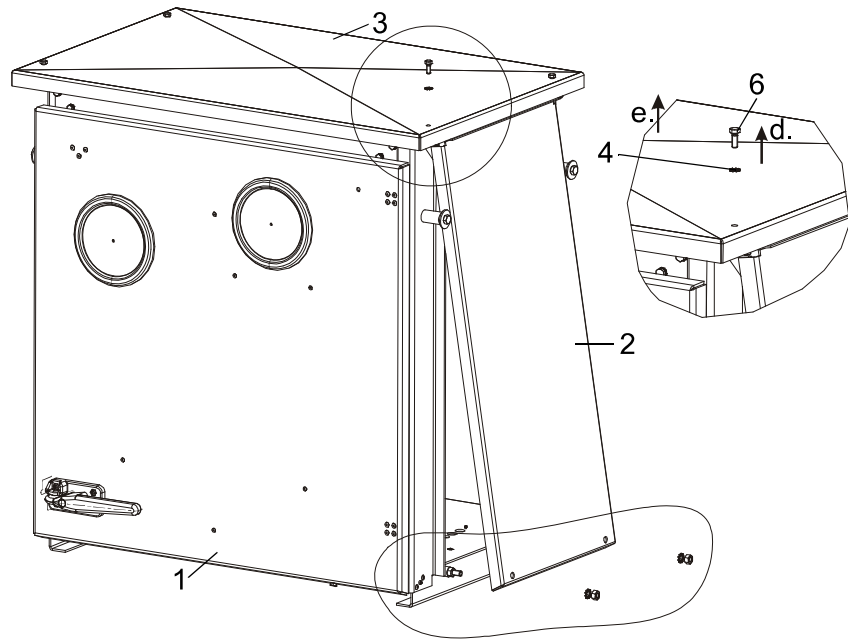

BA-P-ANTRIEBSEITENBLECHAB

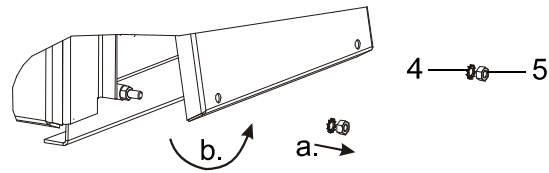

c.

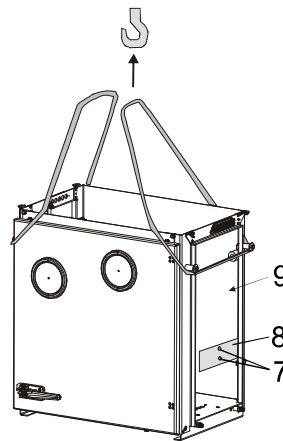

BA-P-ANTRIEB-ANWIEBEN-3

1	Operating mechanism	1x
2	Side panel	2x
3	Roof	1x
4	Tooth lock washer	8x
5	Hexagon nut, M8 A2-70	4x
6	Hexagon bolt, M6 A2-70	4x
7	Hexagon screw, M8x20 8.8	2x
8	Spring guard plate	1x
9	Transport lock (if any)	-

## INSTALLATION

- To lift the operating mechanism, use two slings and the locating pins on the side surfaces of the mechanism.
- Loop one end of each sling under two locating pins and hook the other end in the crane hook.
- Lift the operating mechanism (1) and position it in front of the base frame.
- Lubricate four bolts (14) as per L1 and insert them along with washers (12) into the mechanism from the base frame side.
- Screw nuts (13) and washers (12) loosely on the four bolts inside the mechanism.
- Push the mechanism as far to the left as possible in the direction of pole B and tighten the four nuts to a torque of 196Nm.
- Replace the spring guard plate (8) and fasten it to the mechanism using two screws (7). Tighten to a torque of 23Nm.

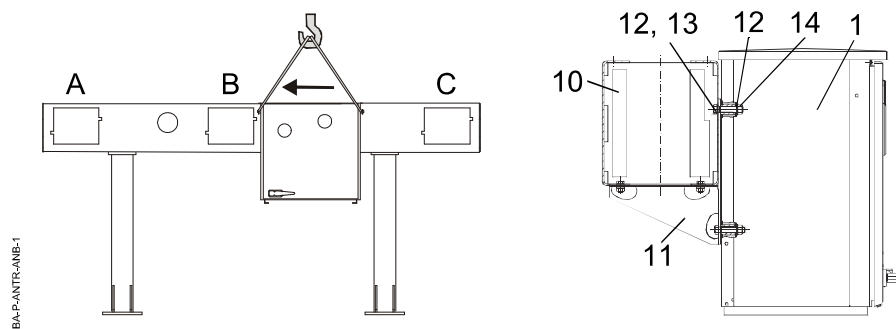

1	Operating mechanism	1x
10	Base frame	1x
11	Mechanism bracket	2x
12	Washer, 16 A2	8x
13	Hexagon nut, M16 A2-70	4x
14	Hexagon bolt, M16x90 8.8 TZN	4x

6.9 Installing the Pole Columns

The operations described in this section must be carried out in sequence for each of the three pole columns. The poles themselves can be installed in any order desired.

6.9.1 Erecting the Pole Columns

**CAUTION**

The filling connection (2) of the pole column (1) must face upward during the erection procedure. If the filling connection faces downward, it could be easily damaged during erection.

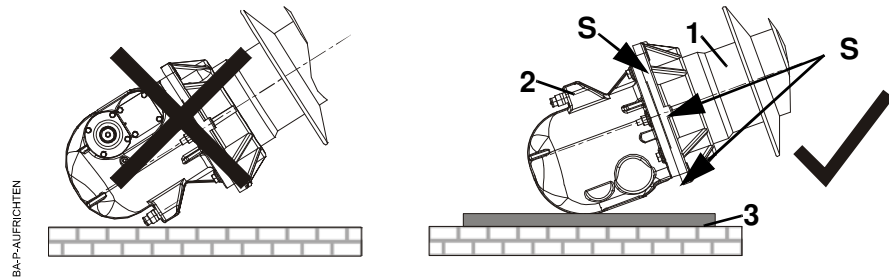

1	Pole column	-
2	Filling connection	-
3	Wooden board	Not supplied

- Check the serial number (S) and identifying pole letter on the lower insulator flange or on the crankcase flange
- Check to make sure the serial number agrees with the breaker serial number.
- Place a wooden board (3) under the rounded area at the bottom of the pole column. This will protect the pole column during the erection process.
- Fasten the lifting tackle to the pole column using two M16 eyebolts. Use the two middle holes in the terminal pad mounting plate for this purpose.

**WARNING**

Falling loads can result in serious personal injury and damage to the breaker.

**Therefore:**

- **Never lift the pole columns from the high voltage terminal pads attached to the pole column. Always use the holes in the terminal pad mounting plate.**
- **Do not stand under suspended loads.**

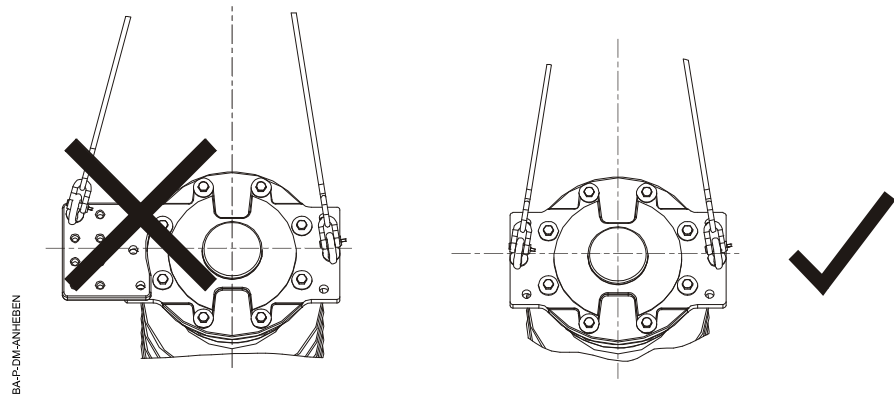

- Hoist the pole column to an upright position, carefully rolling it on the rounded crankcase end.

## 6.9.2 Positioning the Pole Columns

- Find the proper pole position on the base frame (A, B or C as viewed from the mechanism side; see illustration) and place the pole column in this position above the base frame.
- Slowly lower the pole column. While lowering the pole column, turn it slightly on its axis in order to avoid damage. Pay special attention to the gas piping in the base frame.
- Lubricate the four pole column mounting bolts (4) as per L1 and insert them from below. Screw on the nuts to the end of the thread and then loosen them again one half revolution. Do not tighten the nuts yet. The pole columns will be moved again on the base frame during later alignment operations.
- Brace the tire lever (6) against the underside of the base frame and push the pole column back until it hits the stop. This will allow the linkage that will be installed later to be precisely aligned.

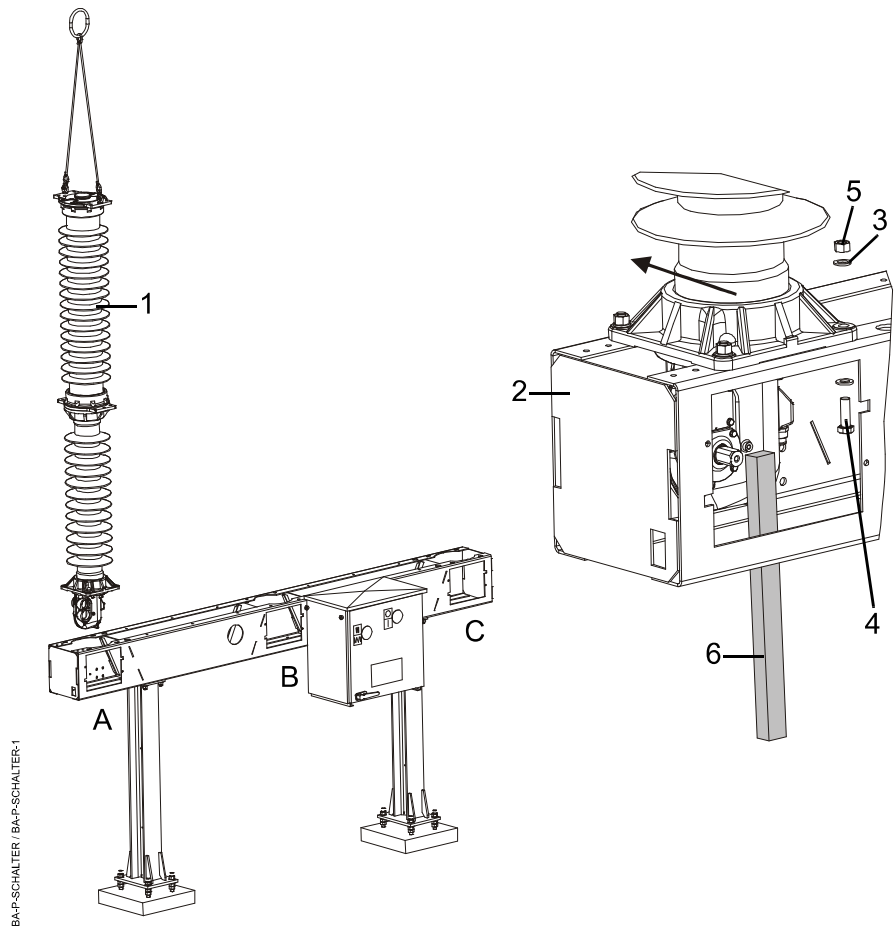

1	Pole column	1x
2	Base frame	1x
3	Washer, 16 A2	8x
4	Hexagon bolt, M16x55 8.8 TZN	4x
5	Hexagon nut, M16 A2-70	4x
6	Tire lever	Not supplied

The opening springs are located in the crankcases of the pole columns. The opening springs fix the pole columns in open position. All other installation steps are based on this open position of the pole columns.

## 6.10 Aligning and Connecting the Pole Columns

The pole column shafts are connected to the levers via a square profile. The levers can therefore only be mounted in four positions. Attach the levers as shown in the following diagrams. No additional positioning aids are required.

The tolerance allows for a slight clearance between the levers and the shafts.

When installation and commissioning are carried out at the manufacturer's plant, the clearance is reduced by turning the levers in the closing direction during the connection process until the levers are in contact with the shafts.

In order to reproduce the routine test values measured at the factory as accurately as possible when commissioning the circuit breaker, we recommend that the clearance be reduced in the same way during installation.

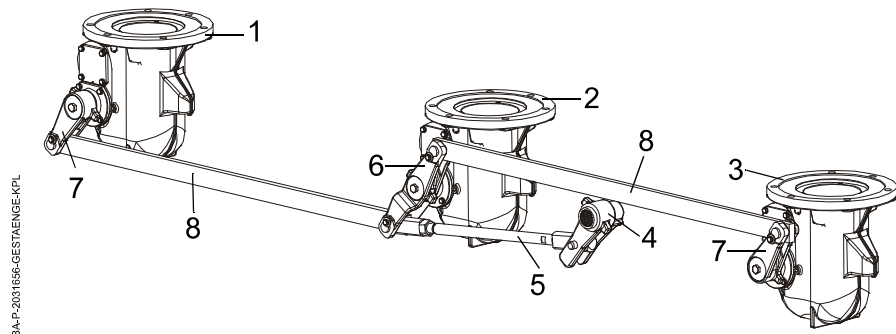

Breaker linkage: overview

1	Pole A	-
2	Pole B	-
3	Pole C	-
4	Drive lever	-
5	Drive rod	-
6	Lever B	-
7	Lever A/C	-
8	Connecting rod	-



**6.11 Aligning and Connecting Pole Column B**

- Check the serial number of the drive rod (see sticker on rod).
- Check to make sure the serial number agrees with the breaker serial number.

The drive rod has already been set to the correct length and the setting marked with lead sealing paint. This setting must not be changed during installation.

The drive lever has been mounted on the operating mechanism at the factory.



Any change in the setting of the drive rod from the manufacturer's marking may cause the circuit breaker to malfunction.

**Therefore:**

- **Do not change the rod length.**
  - **Never use a drive rod with a different breaker serial number.**
-

## 6.11.1 Connecting the Drive Rod to the Drive Lever

- Lubricate the flanged coupling pin (14) as per L2.
- Connect the drive rod (5) and the drive lever (4) using the flanged coupling pin (14), while maintaining the installation position of the drive rod. The side of the drive rod with the hexagon nut faces Pole B.
- Apply locking adhesive S1 to the screw (13).
- Lock the flanged coupling pin (14) using the locking sleeve (11), washer (12) and screw (13). Tighten to a torque of 7Nm.

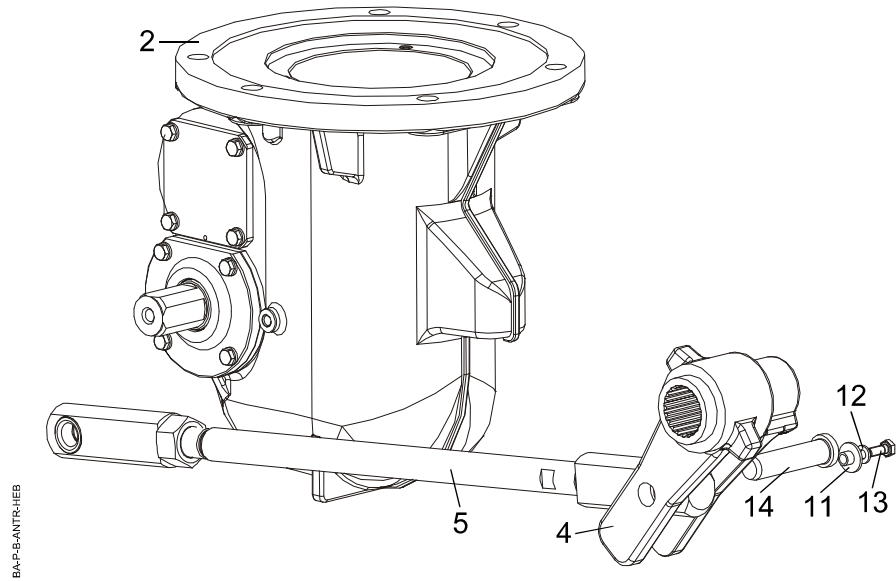

2	Pole B	1x
4	Drive lever	1x
5	Drive rod	1x
11	Locking sleeve	1x
12	Washer, 6 A2	1x
13	Hexagon screw, M6x16 A2-70	1x
14	Flanged coupling pin, 16x68	1x

**6.11.2 Connecting the Drive Rod to Pole B**

- Lubricate the shaft of pole B as per L2.
- Fit lever B (6) onto the shaft of pole B (2).
- Apply locking adhesive S1 to the screw (9). Secure the lever with the screw (9) and washer (10). Tighten to a torque of 35 Nm.
- Insert the drive rod (5) into lever B (6).
- Turn lever B (6) in the direction of the arrow until the lever and the shaft are in contact with one another. This reduces the clearance between the lever and the shaft.
- Pull on the drive rod to reduce the clearance between the drive shaft and operating lever.
- Check to make sure the holes in the lever and drive rod are aligned.

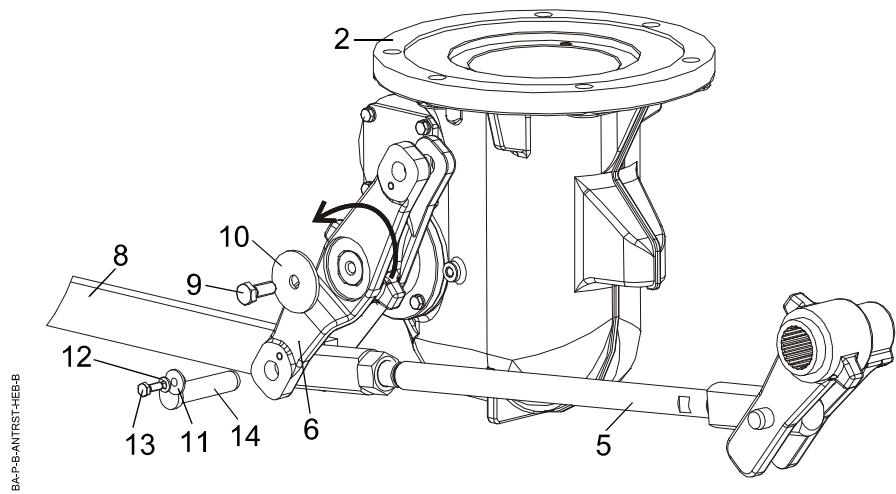

2	Pole B	1x
5	Drive rod	1x
6	Lever B	1x
8	Connecting rod	1x
9	Hexagon screw, M10x25 A2-70	1x
10	Washer, 50.5/11/3	1x
11	Locking sleeve	1x
12	Washer, 6 A2	1x
13	Hexagon screw, M6x16 A2-70	1x
14	Flanged coupling pin, 16x68	1x

BA-P-MONTIERHEBEL-POL-B

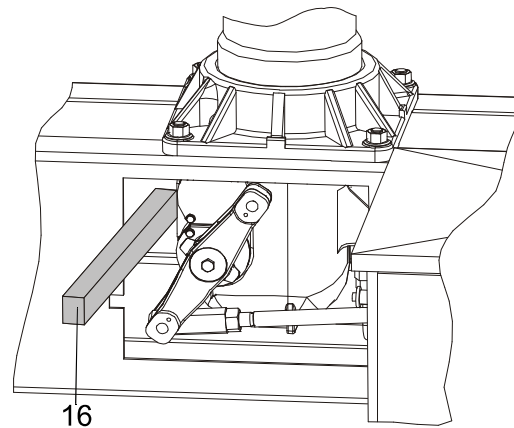

- Brace the tire lever (16) against the side of the base frame or support and push the pole column until the holes in lever B (6) and the drive rod (5) are aligned. Lubricate the flanged coupling pin (14) as per L2. The flanged coupling pin (14) must slide in easily.
- Insert the connecting rod (8) into the base frame through the hole on the left side of the base frame.
- Remove the tire lever and flanged coupling pin (14) again, and also insert the connecting rod (8) leading to pole A into lever B (6) (the connecting rods to the outer poles are identical).
- Connect lever B (6), the drive rod (5) and the connecting rod (8) using the flanged coupling pin (14).
- Apply locking adhesive S1 to the screw (13).
- Lock the flanged coupling pin (14) using the locking sleeve (11), washer (12) and screw (13). Tighten to a torque of 7Nm.
- Complete the connection between pole column B and the base frame by tightening the four pole column mounting bolts to a torque of 146Nm.

**6.11.3 Connecting the Lever to the Connecting Rod for Pole C**

- Insert the connecting rod (8) into the base frame through the hole on the right side of the base frame.
- Insert the connecting rod (8) leading to pole C into the upper slot of lever B (6).
- Lubricate the flanged coupling pin (15) as per L2.
- Connect lever B (6) and the connecting rod (8) using the flanged coupling pin (15).
- Apply locking adhesive S1 to the screw (13).
- Lock the flanged coupling pin (15) using the locking sleeve (11), washer (12) and screw (13). Tighten to a torque of 7Nm.

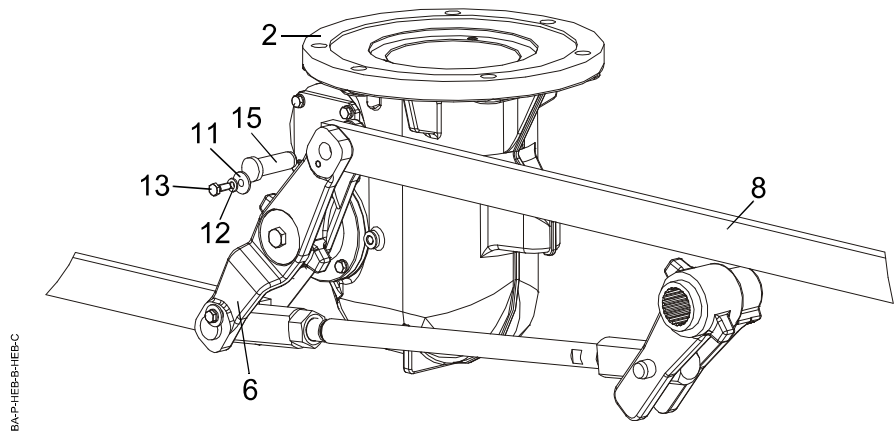

2	Pole B	1x
6	Lever B	1x
8	Connecting rod	1x
11	Locking sleeve	1x
12	Washer, 6 A2	1x
13	Hexagon screw, M6x16 A2-70	1x
15	Flanged coupling pin, 16x47	1x

## 6.11.4 Aligning and Connecting Pole Column A

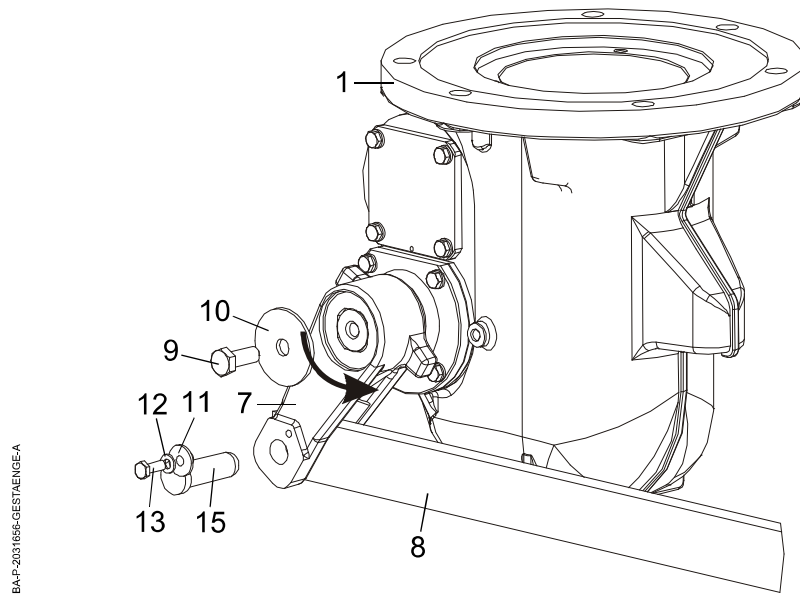

1	Pole A	1x
7	Lever A/C	1x
8	Connecting rod	1x
9	Hexagon screw, M10x25 A2-70	1x
10	Washer, 50.5/11/3	1x
11	Locking sleeve	1x
12	Washer, 6 A2	1x
13	Hexagon screw, M6x16 A2-70	1x
15	Flanged coupling pin, 16x47	1x

- Lubricate the shaft of pole A as per L2.
- Fit lever A/C (7) onto the shaft of pole A (1).
- Apply locking adhesive S1 to the screw (9). Secure the lever with the screw (9) and washer (10). Tighten to a torque of 35Nm.
- Lubricate the flanged coupling pin (15) as per L2.
- Insert the connecting rod (8) into lever A/C (7).
- Turn lever A/C (7) in the direction of the arrow until the lever and the shaft are in contact with one another. This reduces the clearance between the lever and the shaft.
- Brace the tire lever (16) against the side of the base frame or support and push the pole column until the holes in lever A/C (7) and the connecting rod (8) are aligned. The flanged coupling pin (15) must slide in easily.
- Apply locking adhesive S1 to the bolt (13).
- Lock the flanged coupling pin (15) using the locking sleeve (11), washer (12) and screw (13). Tighten to a torque of 7Nm.
- Complete the connection between pole column A and the base frame by tightening the four pole column mounting bolts to a torque of 146Nm.

**6.11.5 Aligning and Connecting Pole Column C**

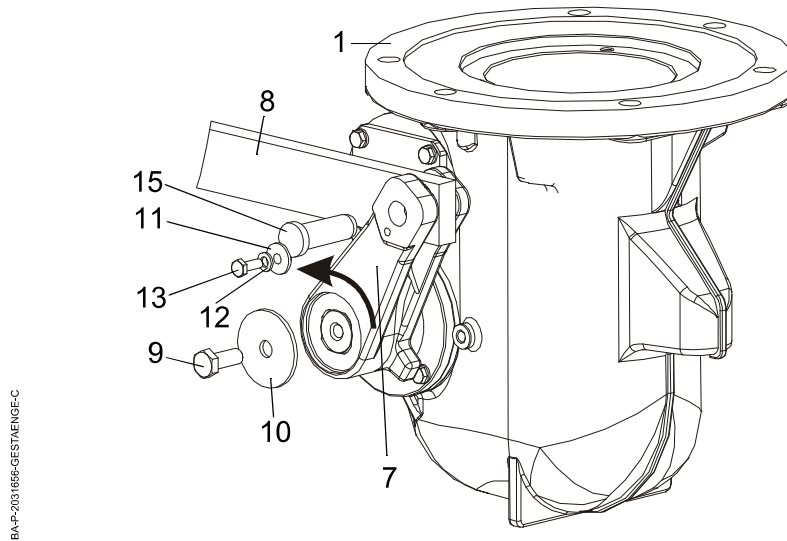

BA-P-2031656-GIESTAENGE-C

1	Pole C	1x
7	Lever A/C	1x
8	Connecting rod	1x
9	Hexagon screw, M10x25 A2-70	1x
10	Washer, 50.5/11/3	1x
11	Locking sleeve	1x
12	Washer, 6 A2	1x
13	Hexagon screw, M6x16 A2-70	1x
15	Flanged coupling pin, 16x47	1x

- Lubricate the shaft of pole C as per L2.
- Fit lever A/C (7) onto the shaft of pole C (1).
- Apply locking adhesive S1 to the screw (9). Secure the lever with the screw (9) and washer (10). Tighten to a torque of 35Nm.
- Lubricate the flanged coupling pin (15) as per L2.
- Insert the connecting rod (8) into lever A/C (7).
- Turn lever A/C (7) in the direction of the arrow until the lever and the shaft are in contact with one another. This reduces the clearance between the lever and the shaft.
- Brace the tire lever (16) against the side of the base frame or support and push the pole column until the holes in lever A/C and the connecting rod are aligned. The flanged coupling pin (15) must slide in easily.
- Apply locking adhesive S1 to the screw (13).
- Lock the flanged coupling pin (15) using the locking sleeve (11), washer (12) and screw (13). Tighten to a torque of 7Nm.
- Complete the connection between pole column C and the base frame by tightening the four pole column mounting bolts to a torque of 146Nm.

## 6.12 Mounting the High Voltage Terminal Pads

The high voltage terminal pads are shipped in the box containing the accessories. The high voltage terminal pads may be mounted either on the front or the rear of the circuit breaker, as desired. Oxide films can form on the terminal pad mounting plates and the high voltage terminal pads during transport and storage, and these films can result in higher contact resistances. Oxide films in the contact areas must be removed before installation. Use a wire brush with stainless steel bristles as the appropriate tool for this job.

- Brush the contact surfaces of the high voltage terminal pads (2) and terminal pad mounting plates (1) until all oxide film has been removed.
- Lubricate contact surfaces on both sides in accordance with lubrication specification L3.
- Lubricate bolts per lubrication specification L1.
- Bolt the high voltage terminal pads to the terminal pad mounting plates using three bolts each (4), washers (3) and nuts (5). Tighten to a torque of 146Nm.

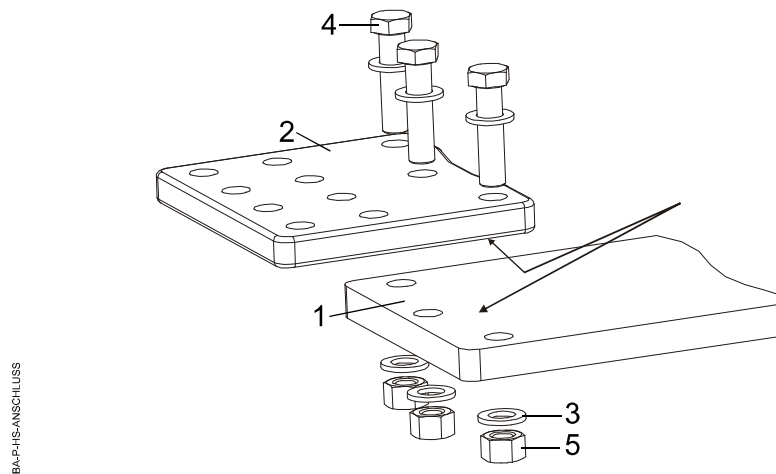

1	Terminal pad mounting plates	1x
2	High voltage terminal pads	1x
3	Washer, 16 A2	6x
4	Hexagon bolt, M16x65 A2-70	3x
5	Hexagon nut, M16 A2-70	3x



6.13 Connecting the Cables



Improper connection of cables can pose a threat to personnel and system safety.  
The individual responsible for safety must give approval for connecting the cables.



When connecting the cables after filling the circuit breaker to rated pressure, there is the danger that insulators will burst if they have been damaged.

**Therefore:**

- **The cables may only be connected by qualified personnel using extreme caution.**

To avoid working on gas-filled pole columns, we recommend that the cables (1) be connected to the circuit breaker's high voltage terminal pads (2) before the pole columns are filled with gas. The ends of the cables facing away from the circuit breaker (1a) must not be connected yet.

Cable ends (1a) must not be in contact with earth potential (potential to ground) simultaneously during later commissioning tests. The resulting auxiliary circuit would affect the test results.

- Brush the contact surfaces of high voltage terminal pads (2) and cable clamp (1) until all oxide film has been removed.
- Lubricate contact surfaces on both sides in accordance with lubrication specification L3.
- Bolt high voltage terminal pads and cable clamp together.
- Keep cable end (1a) isolated from earth potential (potential to ground).

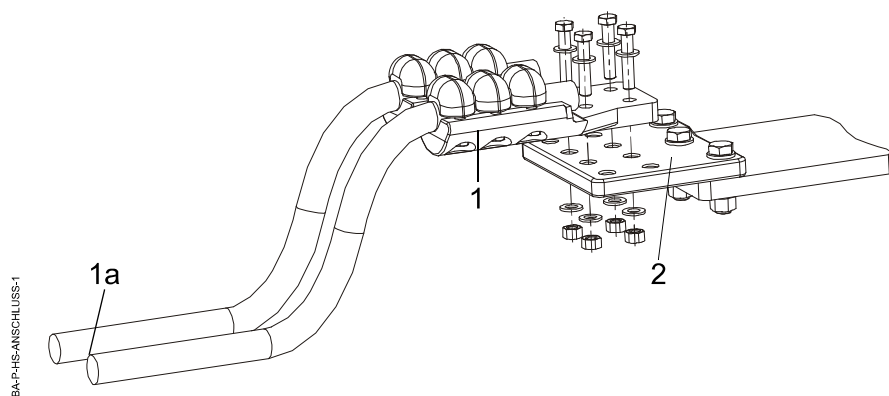

1	Cable with cable clamp	1x
1a	Cable, end facing away from breaker	-
2	High voltage terminal pads	1x

### **6.14 Earthing (Grounding) the Circuit Breaker**

The base frame and supports are equipped with earth connections (ground connections). Pole columns and operating mechanisms are conductively connected via their mounting points to the base frame and earthed or grounded through it (the earthing surfaces are shown in the dimensioned drawing).

- Earth (ground) the base frame and supports.

## 7 Commissioning



Serious personal injury or property damage can result during commissioning if the equipment is live or energized.

**Therefore:**

- **Make sure that the circuit breaker is disconnected from the high voltage system.**
- **Make sure the circuit breaker is earthed (grounded).**

The five safety rules of electrical engineering must be followed:

- Disconnect the equipment from the power supply.
- Install safeguards to ensure that the power cannot be turned on again.
- Confirm that the equipment is de-energized.
- Earth (ground) and short-circuit the equipment.
- Cover or provide barriers for adjacent energized equipment.

### 7.1 Density Monitor

#### 7.1.1 Connecting the Cable

The cable is already connected to the density monitor. The cable entry gland is located on the rear or underside of the operating mechanism.

- Insert the cable into the operating mechanism through the cable gland and connect it according to the schematic diagram.

## 7.1.2 Checking the Operating Points of the density monitor

In one equipment version, the switchgear is available with a density monitor unit of type **EasyCheck**.

The **EasyCheck** technology makes it particularly easy to perform the emission-free density monitor test in correspondence with the "F-gases regulation EU 517/2014" quickly and safely. (see "**EasyCheck Density Monitor Unit**" on Page 107)



### Caution!

For inspection of the density monitor, the gas piping must not be coupled to the pole columns yet.

The density monitor is temperature-compensated. The ambient temperature does not affect the indication or the operating points. For a check of the operating points, only the gas piping is filled with gas. The pole column connections for the gas piping are equipped with check valves. The check valves prevent uncontrolled gas leakage.

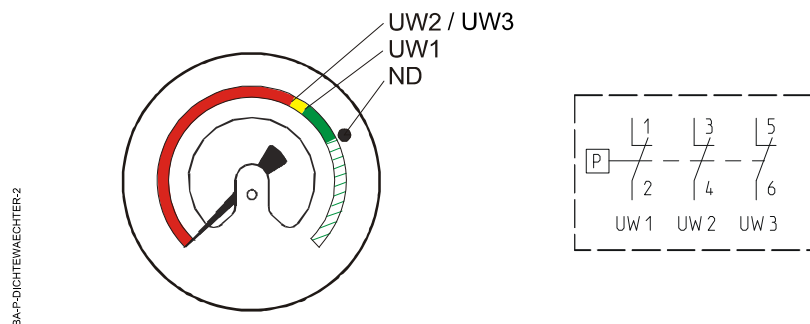

The density monitor has two operating points:

- UW1: Alarm. This signals gas loss, but the circuit breaker remains ready for operation.
- UW2: Lockout. Severe gas loss is indicated, and switching operations are prevented by the electrical control system.
- ND: Rated pressure.

- Unscrew the protective cap from the central supply connection.
- Connect the filling hose of the gas-filling device to the central supply connection (type DILO DN8 coupling; the location of the gas-filling device is shown in the dimensioned drawing).
- Fill the gas piping with SF<sub>6</sub> until rated pressure (ND) is reached. The rated pressure is marked by the black dot on the indicator dial.
- Disconnect and remove the filling hose.

- Connect a device suitable for discharging and collecting SF<sub>6</sub> - such as the SF<sub>6</sub> Multi-Analyzer manufactured by DILO Armaturen und Anlagen GmbH - to the central supply connection.
- Connect the multimeter to the terminals for UW1 in the operating mechanism.
- Slowly reduce the gas pressure in the piping until UW1 is reached. As you do so, compare the electric operating point with the density monitor indication.
- Connect the multimeter to the terminals for UW2.
- Reduce the gas pressure further until UW2 is reached. As you do so, compare the electric operating point with the density monitor indication.



*Instruction!*

The escaping gas must be collected (e.g. with the SF<sub>6</sub>-multi analyser by DILO).

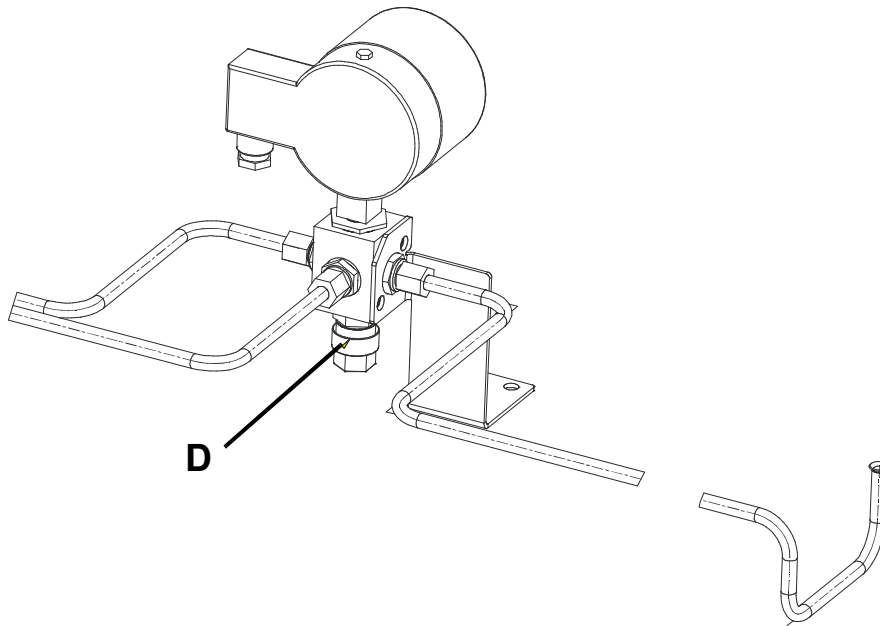

D	Central supply connection / filler block
---	--

### 7.2 Filling the Pole Columns with Gas (Preparation)

---



The pressurized components of the pole columns can be damaged by improper handling. If the components are damaged, they may burst when the gas pressure is increased. This can result in serious personal injury or property damage.

**Therefore:**

- **Inspect the pole columns visually for damage before beginning the filling operation.**
  - **Carry out the filling operation from a protected position.**
- 

#### CAUTION

If the rated pressure is exceeded, it may cause the pressure relief device to respond.

**Therefore:**

- **Never set the pressure reducing valve of the gas-filling device higher than the rated breaker pressure.**
- 

The rated pressure (ND) is shown on the nameplate and the density monitor (black dot on the density monitor indicator).

If there is any doubt about the gas quality, always check it (**see “Checking the Gas Quality” on Page 79**).

Contamination of breaker gas by foreign gases is not permitted. Make sure that the filling hose is filled with SF<sub>6</sub> before the filling operation. In case of doubt, purge the filling hose before the filling operation.

The density monitor indication can be checked using a test manometer and a thermometer. The indicated value of the test manometer must be corrected as a function of the ambient temperature in accordance with the SF<sub>6</sub> pressure curve.

---

## 7.2.1 Establish Gas Connections between Density Monitor and Pole columns

---

In one equipment version, the switchgear is available with a gas connection of type **FlexLink**.

The **FlexLink** technology makes it particularly easy to couple the gas connections to the pole columns. (*see “FlexLink-Gas Connection” on Page 111*)

---

We recommend that the following tools be used to connect the gas couplings:

- T022: Compact open-end wrench (open-ended spanner), SW27
  - WK001: Torque wrench (spanner) with ratchet adapter and SW27 open-end wrench head
- 
- Remove the protective caps from the gas couplings on the pole columns and the gas piping.
  - Grease the threads of the gas couplings as per L4.
  - Connect the gas piping to all pole columns. The filling connections are equipped with threads for this purpose. First screw on the filling connections by hand, then tighten provisionally using tool T022, and finally tighten using tool set WK001 to a torque of 30 Nm. Use two wrenches for connecting the filling connections.
  - Retighten all couplings in the gas piping system.

## 7.3 Filling the Breaker with Gas



All pressure specifications are given in terms of relative pressure ( $p_e$ ).

- Connect the filling hose of the gas-filling device (gas cylinder with pressure-reducing valve or gas handling cart) to the central supply connection (type DILO DN8 coupling).
- Fill the circuit breaker gradually until rated pressure is reached. Never set the pressure-reducing valve higher than the rated breaker pressure.
- After a temperature equalization period of approximately 1 hour, check the gas pressure again and correct it, if necessary.
- Check all gas piping seals for leaks using a leak detector.
- Screw on the protective cap for the central supply connection.

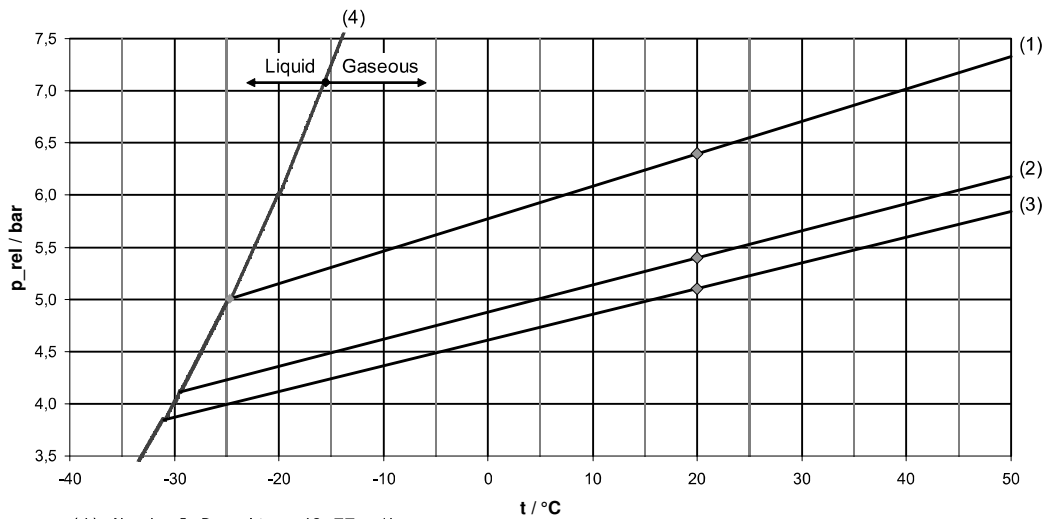

(1)=Nominal Density 48,77 g/L  
 (2)=Alarm Density 41,58 g/L  
 (3)=Lockout Density 39,46 g/L  
 (4)=Liquifaction Curve

SF<sub>6</sub> pressure curve -30°C

(ND =0.64 MPa [ $p_e$ ] / UW1=0.54 MPa [ $p_e$ ] / UW2=0.51MPa [ $p_e$ ])

1	Rated pressure curve	-
2	Alarm pressure curve	-
3	Lockout pressure curve	-
4	SF <sub>6</sub> liquefaction curve	-



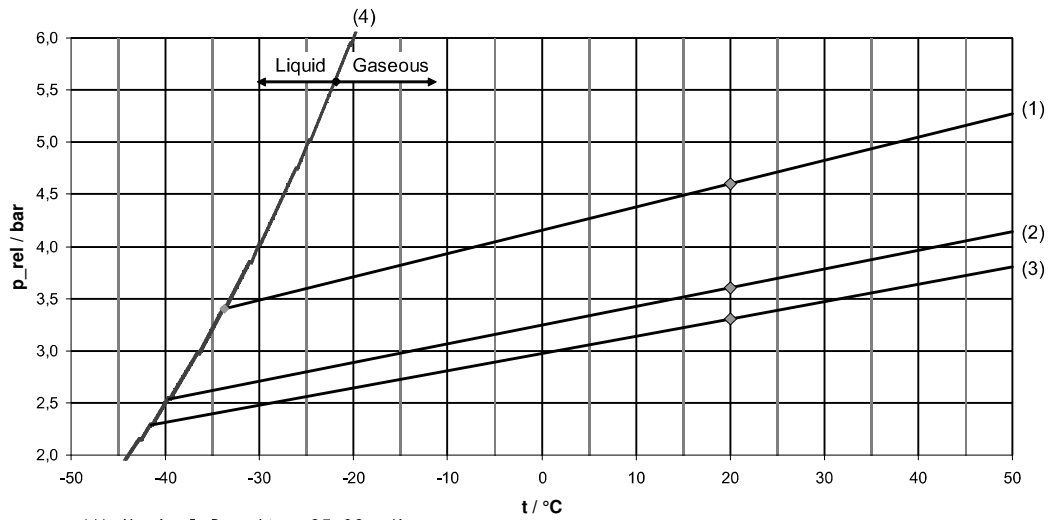

- (1)=Nominal Density 35,98 g/L
- (2)=Alarm Density 29,16 g/L
- (3)=Lockout Density 27,15 g/L
- (4)=Liquifaction Curve

SF<sub>6</sub> pressure curve -40°C

(ND =0.46 MPa [p<sub>e</sub>] / UW1=0.36 MPa [p<sub>e</sub>] / UW2=0.33 MPa [p<sub>e</sub>])

1	Rated pressure curve	-
2	Alarm pressure curve	-
3	Lockout pressure curve	-
4	SF <sub>6</sub> liquefaction curve	-

We recommend that the gas cylinder be weighed before and after the filling operation and that the weight difference be compared with the gas weight specified on the nameplate. This makes it possible to verify that the filling process has been carried out correctly.

### 7.4 Checking the Anti-Condensation Heater

Measure the resistance of the anti-condensation heater at the terminals in the operating mechanism and compare it with the reference value in the routine test certificate. Enter the values in the checklist.

### 7.5 Connecting the Supply and Control Cables



Serious personal injury or property damage can result during commissioning if the equipment is live or energized.

**Therefore:**

- **Make sure the supply and control cables are not live before connecting them.**
- 



The mechanism's charging process will begin immediately after the supply and control voltages are connected.

**Therefore:**

- **Keep parts of the body and other objects away from the moving parts of the operating mechanism and the entire connecting linkage.**
- 



The anti-condensation heater will heat up after the supply and control voltages are connected. Touching the anti-condensation heater can result in burns.

**Therefore:**

- **Do not touch the anti-condensation heater.**
- 

- Insert the supply and control cables through the cable entry plate on the underside of the operating mechanism. This plate must be fitted with cable glands by the station (and can be removed for repairs or maintenance). Connect the cables in accordance with the schematic diagram.

---

## 7.6 Functional Testing

---

**CAUTION**

Operations at gas pressures below UW2 can result in mechanical damage to the circuit breaker.

**Therefore:**

- **Never operate the circuit breaker at gas pressures below UW2 (red area on the density monitor indicator).**
- 



The pressurized components of the pole columns can be damaged by improper handling. Such damage can cause the pole columns to burst as the result of breaker vibrations. This can result in serious personal injury or property damage.

**Therefore:**

- **Always carry out test operations from a protected position.**
- 

**CAUTION**

Long-lasting applied voltage may damage the shunt release coils.

**Therefore:**

- **Connect coils only by way of the terminals provided.**
  - **Apply voltage to the coils for no longer than three seconds.**
- 

### 7.6.1 Test Operations

- Carry out five closing and five opening operations by remote control.

### 7.6.2 Measuring the Running Time of the Charging Motor

After each closing operation, the charging motor automatically recharges the closing spring.

- Carry out a closing operation and measure the running time of the charging motor.
- Compare the running time with the reference values in the routine test certificate and enter it in the checklist.

### 7.6.3 Measuring the Contact Resistance

- Connect the measurement and supply leads to the **high voltage terminal pads**.
- Measure the contact resistance (> 100A DC).
- Compared the measured contact resistance with the reference values in the routine test certificate and enter it in the checklist.

If the contact resistances are higher than the values given in the routine test certificate, repeat the measurement on the **terminal pad mounting plate**.

- Connect the measurement and supply leads to the terminal pad mounting plate.
- Measure the contact resistance (> 100A DC).
- Compared the measured contact resistance with the reference values in the routine test certificate and enter it in the checklist.

If these measured values now correspond to those in the routine test certificate, then the error is due to incorrect installation of the high voltage terminal pads (*see “Mounting the High Voltage Terminal Pads” on Page 48*).

### 7.6.4 Measuring the Operating Times

#### **Closing time:**

From the start of the electrical tripping pulse until the contacts touch.

#### **Opening time:**

From the start of the electrical tripping pulse until the contacts separate.

- Connect the operating time measuring device to the pole column terminal pads.
- Carry out a closing operation and measure the pole column operating times.
- Carry out an opening operation and measure the pole column operating times.
- Compare the measured operating times with the reference values in the routine test certificate and enter them in the checklist.

7.6.5 Checking Manual Operation



Manual operation bypasses any circuit breaker interlock system.

**Therefore:**

- **Make sure that the gas pressure in the circuit breaker corresponds at least to the UW2 value before beginning manual operation.**

The manual operating levers are protected against accidental operation by a locking plate.

- Loosen the locking bolts (1) one full turn and push the locking plate (2) down and to the left.
- Carry out one closing operation and one opening operation using the manual operating levers. The circuit breaker will immediately carry out the corresponding operation.
- Push the locking plate up and to the right, and tighten the two locking bolts again.

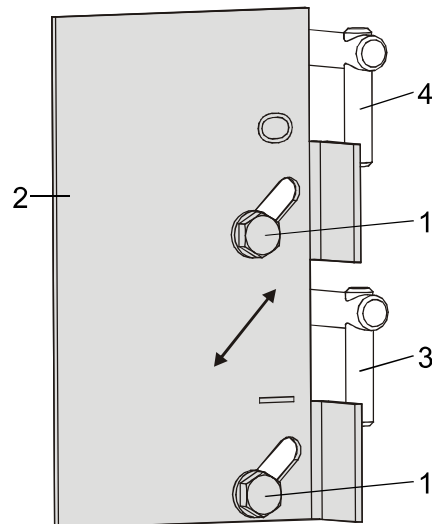

BA-P-HANDSFERRE

1	Locking bolt	-
2	Locking plate	-
3	Manual operation for closing operation	-
4	Manual operation for opening operation	-

### 7.6.6 Manually Charging the Closing Spring

- Check the operating state of the circuit breaker and the mechanism:
  - Closing spring discharged.
  - Breaker either in closed or open position.
  - Control voltage disconnected.
- Open the door of the mechanism.
- Using the hand crank (70.53), turn the gearing clockwise until the spring position indicator shows "closing spring charged".

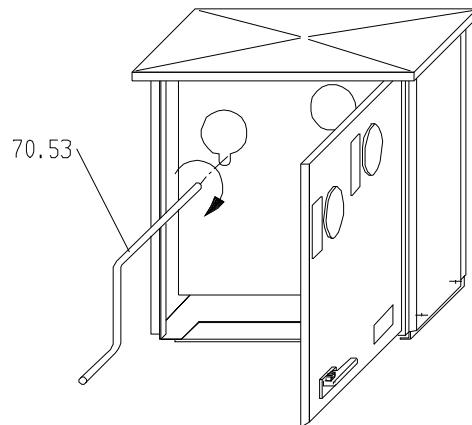

- In this position the gearing is in idling position and can be turned further.
- While the closing spring is being charged, the return stop prevents the crank wheel from slipping backwards when manual charging is interrupted or stopped.
- Close the cabinet door.

### 7.6.7 Checking the Anti-Pumping System

#### Type with Closing Priority (Standard)

- Circuit breaker in open position:
- Apply a continuous electrical opening command and at the same time give an electrical closing command: the circuit breaker will complete just one closing operation and one opening operation.
- Circuit breaker in closed position:
- Apply a continuous electric closing command and at the same time give an electric opening command: the circuit breaker will complete just one opening operation.

#### Type with Opening Priority (Optional)

- Circuit breaker in open position:
- Apply a continuous electrical opening command and at the same time give an electrical closing command: the circuit breaker will not execute a closing operation.
- Circuit breaker in closed position:
- Apply a continuous electric closing command and at the same time give an electrical opening command: the circuit breaker will complete just one opening operation.
- After removal of the opening command, the circuit breaker is not allowed to carry out a closing operation.

The anti-pumping system is automatically reset if there are no more operating commands.

### 7.6.8 Checking the Functional Lockout

The contacts of the density monitor will close when the gas pressure drops.

- Jumper the UW2 density monitor contacts at the terminal strip.
- Give one closing command and one opening command. The circuit breaker must not carry out any switching operations.
- Remove the jumpers from the terminal strip.

### 7.6.9 Operations Counter

- Check the operation of the operations counter.
- Read the count shown on the counter and enter the values in the checklist.

### 7.6.10 Final Tasks

- Remove all testing and measuring equipment from the circuit breaker.
- Replace the roof and side panels of the mechanism after work is completed. Tighten the bolts (6) and nuts (5) to a torque of 17Nm.
- Clean up the installation site.

The breaker is ready to be connected to the high voltage system.





## 8 Troubleshooting

### 8.1 Electrical Switching Commands Are Not Correctly Executed



Work on the control system involves the danger of electric shock. Sudden movements of the charging system or the breaker linkage can cause serious injury.

Troubleshooting tasks should be handled by qualified staff only. Such staff must follow the safety rules of electrical engineering.

- Check the control voltage.
- Check the gas pressure on the density monitor. If the gas pressure is UW2 or less, no switching commands will be executed.
- Check the charging state of the closing spring. If the closing spring is not charged, no closing operations can be carried out. It is possible that a motor protection switch has tripped and disconnected the charging motor from the power supply.
- Check the shunt releases. Replace defective coils, determine the cause of a potential overload and eliminate the cause.
- Check the terminal connections to make sure they are tight and properly connected.
- Check the contactors in the faulty control circuit.
- Check the electric operating points of the density monitor.

### 8.2 Mechanism Reconditioning Procedures

#### 8.2.1 Replacing the Charging Motor

- Disconnect both wires from the motor limit switch.

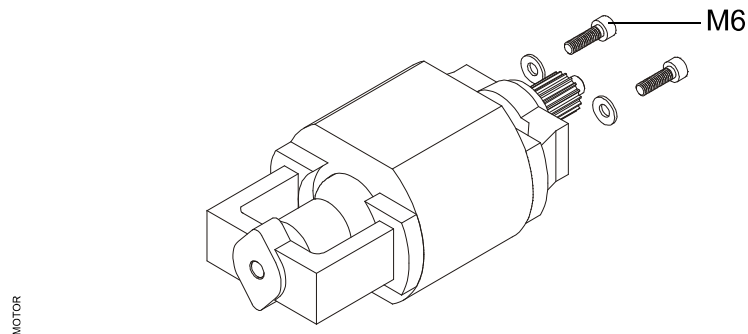

- Unscrew the M6 mounting screws and remove the motor.
- Install the new motor and tighten the mounting screws to a torque of 7Nm.

---

**CAUTION**

Lubrication of the motor pinion may cause the operating mechanism to malfunction.  
Do not grease or lubricate the motor pinion.

---

- Reconnect the wires to the motor limit switch.

---

**CAUTION**

If the wiring is incorrect, the motor will stall and may become damaged.

Turn on the power to the motor briefly and check to see whether the motor drives the gear unit.

**If this is not the case:**

- **Turn off the power to the motor immediately.**
  - **Check the connections and correct if necessary.**
-

8.2.2 Replacing the Closing and Opening Coil

- Disconnect the wire connections from the coil (3).

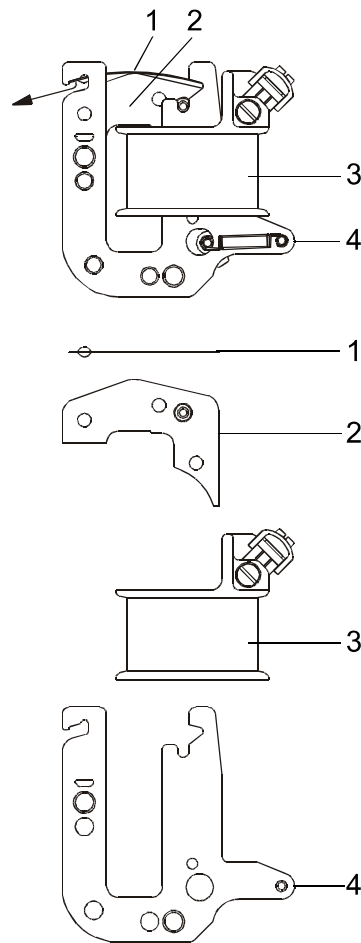

1	Leaf spring	-
2	Yoke	-
3	Coil	-
4	Side plate	-

- Push aside the leaf spring (1) with your finger in the direction of the arrow.
- Lift out the yoke (2) and place it on a clean surface.

**CAUTION**

Remove the coil being replaced and insert a new coil over the side plates (4).

The wrong coil type can cause the mechanism to malfunction.

**Make sure you have the correct coil type. Compare the part number on the coils.**

- Replace the yoke (2) and mount the leaf spring (1).
- Check the fit of the leaf spring (1): it must snap into place.
- Connect the coil (3).

### 8.2.3 Replacing the Operations Counter

- Detach the operating link (1).

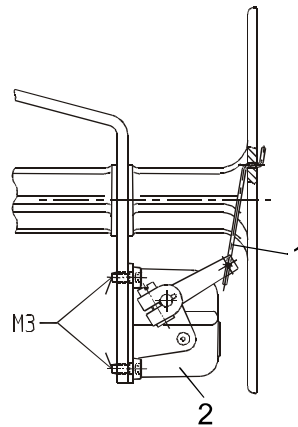

1	Operating link	-
2	Operations counter	-

- Remove the operations counter (2) by unscrewing the four M3 mounting screws.
- Set the new operations counter manually to indicate the number of operations shown on the old operations counter (so that it will be possible later to determine the life of the breaker).
- Mount the new operations counter.
- Reattach the operating link.

**8.2.4 Replacing the Motor Limit Switch and/or the Auxiliary Switch**

- Disconnect the wire connections to the motor limit switch (7) and/or the auxiliary switch (5).

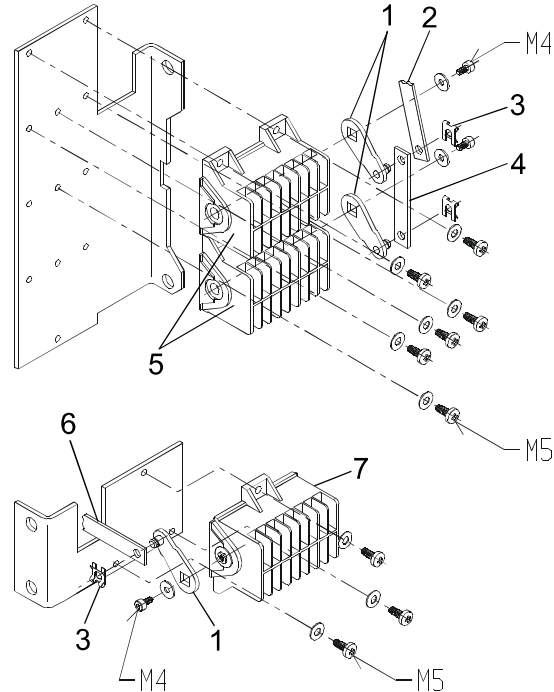

1	Lever	-
2	Drive rod	-
3	Locking clamp	-
4	Connecting rod	-
5	Auxiliary switch	-
6	Drive rod	-
7	Motor limit switch	-

- Remove the locking clamps (3). Remove the drive rod (2 or 6) and the connecting rod (4).
- Unscrew the M5 mounting screws.
- Remove the motor limit switch or auxiliary switch.
- Unscrew the M4 screw(s) and remove the lever (1).
- Mount the lever on the new motor limit switch or auxiliary switch.

**CAUTION**

If the drum controller is positioned incorrectly, operation of the mechanism will be negatively affected.

Therefore check the position of the drum controller.

- **Motor limit switch:** Contacts 15-16 are open in the "closing spring discharged" position.
- **Auxiliary switch:** Contacts 15-16 are closed in breaker position "O".

- 
- Install the motor limit switch (or the auxiliary switch).
  - Tighten the M5 screws.
  - Mount the drive and connecting rods.
  - Reinstall the locking clamps.
  - Tighten the wire connections.
  - Check to see whether there is play in the linkage.

### 8.3 Replacing the Density Monitor

---

In one equipment version, the switchgear is available with a density monitor unit of type **EasyCheck**.

The **EasyCheck** technology makes it particularly easy to perform the emission-free density monitor test in correspondence with the "**F-gases regulation EU 517/2014**" quickly and safely. **Siehe "EasyCheck Density Monitor Unit" auf Seite 107.**

---

The density monitor (1) is connected to the filler block (3) by the threaded bushing (2). The O-ring (4) seals the connection.

The internal thread (female thread) of the threaded bushing is a right-hand thread, whereas the external thread (male thread) is a left-hand thread.

If no density monitor is attached, the check valve (5) closes the hole in the filler block. This makes it possible to replace the density monitor without disconnecting the gas couplings from the pole columns.

- Hold the density monitor firmly and unscrew and remove the threaded bushing from the filler block (**left-hand thread**). Because of the left-hand and right-hand thread combination, the density monitor will move out of the threaded bushing simultaneously.
- Remove the threaded bushing (2) from the old density monitor.
- Replace the O-ring (4). Lubricate the O-ring and sealing surfaces as per L5.
- Lubricate both threads of the threaded bushing as per L4.
- Screw the threaded bushing two full turns onto the new density monitor.
- Place the threaded bushing and density monitor on the filler block. Align the density monitor and screw the threaded bushing into the filler block (**left-hand thread**). Because of the left-hand and right-hand thread combination, the density monitor will move into the threaded bushing simultaneously.
- Tighten the threaded bushing to a torque of 30Nm.
- After installation, there must be a gap (2 to 4mm) between the collar of the threaded bushing and the filler block. The gap ensures that the density monitor will rest securely on the filler block.
- Fill the vent hole (2a) in the threaded bushing with grease as per L4.

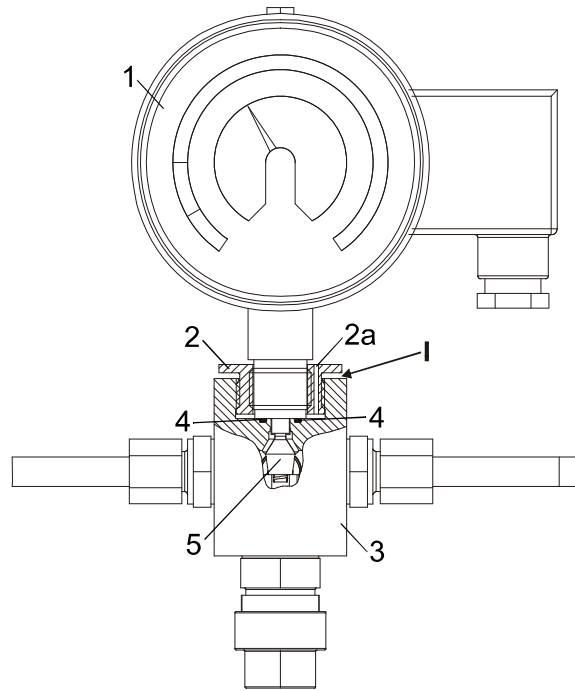

BA-P-DICHTEWECHTER

1	Density monitor	1x
2	Threaded bushing	1x
2a	Vent hole	1x
3	Filler block	1x
4	O-ring	1x
5	Check valve	1x



8.3.1 Austausch einer Gasverbindung

In one equipment version, the switchgear is available with a gas connection of type **FlexLink**.

The **FlexLink** technology makes it particularly easy to couple the gas connections to the pole columns. **Siehe "FlexLink-Gas Connection" auf Seite 111.**

The standard gas connection consists of bent tubes. It is firmly connected to the density monitor unit on one side. The other side has a filling coupling with check valve for connection to the pole columns.

The ends of the gas pipes (1) are flared (1a). The inner surface of the flaring is the sealing surface. The gas pipes are connected by union nuts (1b). The flaring allows the union nuts to be captivated to the gas pipe.

The piping junction points (2) have an external thread and an inside tapered contour (2a). The inside tapered contour forms the sealing surface.

A tubular stiffener (3) stabilizes the joint mechanically. The O-ring (4) fitted onto the stiffener seals the connection.

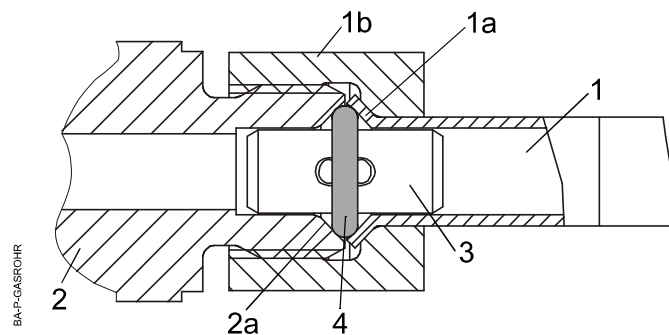

1	Gas pipe	1x
1a	Flaring	-
1b	Union nut	-
2	Junction point	-
2a	Inside tapered contour	-
3	Tubular stiffener	1x
4	O-ring	1x

- Disconnect all filling connections. This will disconnect the gas compartments of the pole columns from the gas piping.
- Unscrew the gas pipe that is to be replaced from the junction points.
- Check the sealing surfaces of the junction points for damage.
- Apply grease to a new O-ring (4) as per L5 and fit onto the tubular stiffener (3).
- Lubricate the sealing areas on the gas pipe and the junction points as per L5.

## **TROUBLESHOOTING**

---

- Lubricate the threads of the junction points as per L4.
- Insert the tubular stiffener and O-ring and screw the gas pipe together with the junction point until it is finger-tight.
- Align the gas pipe and tighten it to a torque of 30Nm.

## 9 Inspection and Maintenance

Inspection and maintenance procedures are carried out according to a schedule.

Reconditioning work is a function of breaker operating frequency and the breaking current load carried by the circuit breaker.

The specified inspection and maintenance intervals apply to normal operating conditions. Extreme ambient conditions such as

- continuously high ambient temperatures,
- heavy dust accumulation,
- continuously high humidity,
- severe air pollution by aggressive gases or vapors,
- and service in coastal areas

may make shorter inspection and maintenance intervals necessary.

The intervals are as follows:

Inspection: On an occasional basis during routine inspections, after 6 years at the latest;

Maintenance: After 12 and 24 years.

---

**CAUTION**

Oil and cleaning additives attack the silicone surface of the insulator.

**Therefore:**

- **Clean and wash the silicone shielding using only water or isopropyl alcohol.**

---

The spring operating mechanisms have already been provided with lifetime lubrication at the factory and are therefore maintenance-free under normal operating conditions.

---

**CAUTION**

Improper relubrication of the mechanisms may lead to problems or cause the mechanism to malfunction.

---

Maintenance and reconditioning may only be performed by trained technicians.

Qualified personnel can be requested from GE. The customer's staff can be trained at the manufacturer's plant. GE offers training courses for this purpose.

## INSPECTION AND MAINTENANCE

The arcing contacts will exhibit wear due to the switching of normal and short-circuit currents. The effective value of the short-circuit breaking current is used to evaluate wear.

Reconditioning is necessary after 2,500 operations at rated normal current or after a specific total breaking current (see figure) has been reached.

### CAUTION

Under certain operating conditions, such as operation of reactors and capacitor banks (especially back-to-back conditions), reconditioning will be necessary after fewer operations.

Special approval by GE is required for service under these conditions.

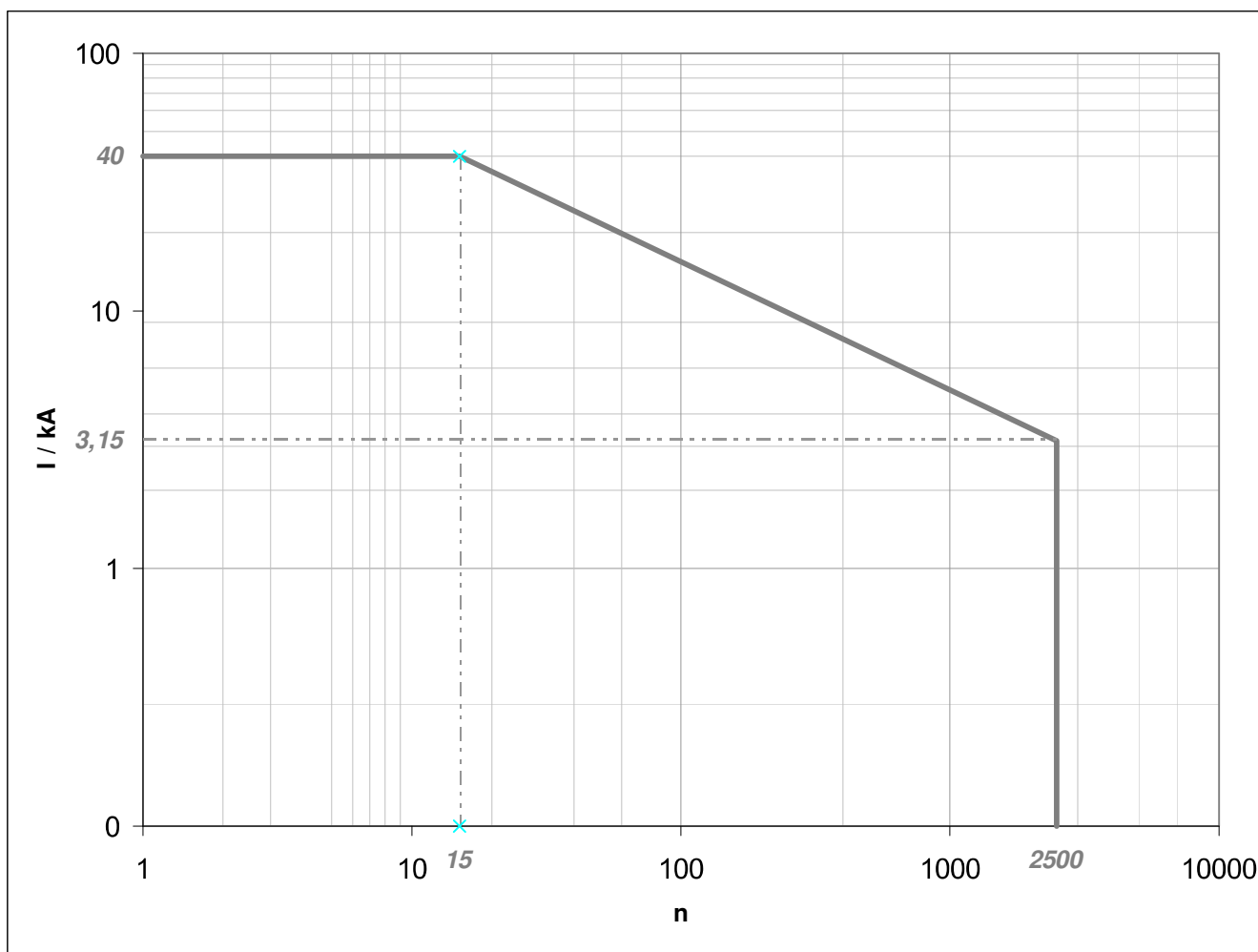

### 9.1 Ordering Accessories and Replacement Parts

The following data are required for an order:

- Type designation on nameplate
- Serial number on nameplate
- Instruction manual number on cover
- Figure number and position number in the figure
- Part description
- Quantity required

### 9.2 Inspection

The circuit breaker may remain in operation during inspection.



Danger due to electric shock.

**Therefore:**

- **Never reach into the high voltage insulation area of the circuit breaker.**
- **Never touch the contacts of the circuit breaker control system.**

Follow all regional and operator-specified safety precautions.

---

#### 9.2.1 Visual Inspection

- Check the circuit breaker carefully for damage or corrosion. In particular, check the insulators from the ground for possible damage.
- If corrosion is detected, take steps to prevent or control corrosion.
- Check the ventilation ports and vents in the mechanism cabinet to make sure they are clear. Remove any blockages.

#### 9.2.2 Anti-Condensation Heater

Check the heat dissipation from the anti-condensation heater. To do so, place a contact thermometer on the anti-condensation heater and measure the temperature rise.



The anti-condensation heating unit gets hot during operation. It can burn skin or clothing.

**Therefore:**

- **Never touch the heating unit directly.**
- 

#### 9.2.3 Checking Gas Pressure

Check the density monitor indicator. If the indicator is not in the green area, top up with gas until rated pressure is reached (**see “Filling the Breaker with Gas” on Page 56**).

### 9.3 Maintenance

The circuit breaker must be shut down for maintenance work. Opening the pole columns is not necessary.

- Disconnect the breaker from the high voltage system, and ground (earth) the breaker at both ends.
- Discharge the closing and opening springs.  
This state is reached when the position indicator shows OPEN and the spring position indicator is on "discharged." The operations shown in the table below are required to reach this state, depending on the starting situation:

Breaker Position	State of the Closing Spring	Operations to Be Executed
CLOSED / I	Charged	O-C-O
CLOSED / I	Discharged	O
OPEN / 0	Charged	C-O
OPEN / 0	Discharged	No operation required



Danger due to electric shock.

**Therefore:**

- **Disconnect the breaker from the high voltage system and ground (earth) the breaker at both ends.**
- 



Danger due to suddenly moving linkage.

**Therefore:**

- **Discharge the closing and opening springs by carrying out closing and opening operations.**
- 

#### 9.3.1 Checking the Cable Connections

- Check to make sure all cable connections in the mechanism housing are tight.

#### 9.3.2 Checking the Connecting Linkage

- Check all the fastening and locking elements (pins, nuts, screws and bolts) on the connecting linkage.

#### 9.3.3 Checking the Control Circuits

- Carry out test operations in accordance with the commissioning procedure (*see "Test Operations" on Page 59*).

**9.3.4 Checking the Gas Quality**

Take a gas sample and check for compliance with the limits.

- Dew point:  $\leq -5^{\circ}\text{C}$  <sup>1)</sup>
- SF<sub>6</sub> content:  $\geq 97\%$
- Acidity (SO<sub>2</sub>):  $< 180$  ppmv <sup>2)</sup>

1) Based on the operating pressure and 20°C.

2) Measurements earliest perform three days after a short circuit.

The required measuring and testing equipment is listed in (**see “Tools and Auxiliary Equipment” on Page 119**).

**9.3.5 Checking the Contact Resistance**

- Check the contact resistance as described in the commissioning section.

**9.3.6 Checking the Operating Times**

- Check the operating times as described in the commissioning section.

**9.3.7 Checking the Threaded Connections**

- Check all accessible threaded connections (screwed or bolted joints) to make sure they are tight.

The tightening torques are given in the following sections:

- Installation
- Commissioning
- Troubleshooting
- Reconditioning





10 Reconditioning



Danger due to electric shock.

**Therefore:**

- **Disconnect the breaker from the high voltage system, and ground (earth) the breaker at both ends.**



Danger due to suddenly moving linkages.

**Therefore:**

- **Discharge the closing and opening springs by carrying out closing and opening operations.**

Isolate and ground (earth) the breaker:

- Discharge the closing and opening springs.  
This state is reached when the position indicator shows OPEN and the spring position indicator is on "discharged." The operations shown in the table below are required to reach this state, depending on the starting situation.
- Disconnect the supply voltage to the motor.

<b>Breaker Position</b>	<b>State of the Closing Spring</b>	<b>Operations to Be Executed</b>
CLOSED / I	Charged	O-C-O
CLOSED / I	Discharged	O
OPEN / 0	Charged	C-O
OPEN / 0	Discharged	No operation required

The equipment should preferably be reconditioned in closed, dry, dust-free rooms. If this is not possible and the equipment has to be reconditioned outdoors, then it should only be done in dry weather when there is no wind.

The circuit breaker is equipped with a disconnect (isolating point) between the interrupter chamber and the post insulator. All interrupter chambers are interchangeable. This design makes it possible to replace entire interrupter chambers quickly and then recondition the interrupter chambers in closed rooms.

All functional elements must be inspected and cleaned with a cleaning cloth soaked in alcohol.

If sealing bonds or gasketed joints are opened during these operations, then the respective elastomer gaskets or seals must be replaced.

## RECONDITIONING

---

The adsorption filter in each pole column that is opened must be replaced.

---

**CAUTION**

The period during which the gas compartments are open should be kept to a minimum.  
The ingress of water (rain) must be prevented at all times.

---

### 10.1 Reconditioning the Interrupter Chamber

#### 10.1.1 Disconnecting the Interrupter Chamber from the Post Insulator

---

 **WARNING**

- After electrical operations, SF<sub>6</sub> may contain noxious or toxic substances and is a greenhouse gas.
- Therefore never discharge SF<sub>6</sub> to the atmosphere.
- Draw off the SF<sub>6</sub> gas into a gas cylinder using a service unit and send it to reprocessing.

---

For this procedure, the pole column must be in the closed position.

- Draw off the SF<sub>6</sub> gas using a service unit, and evacuate and ventilate the breaker.
- Fasten the lifting tackle to the pole column using two M16 eyebolts. Use the two middle holes in the terminal pad mounting plate for this purpose.
- Install the slow operation device in the operating mechanism and slowly move the mechanism to the closed position (**see “Slow Operation for Maintenance Purposes” on Page 137**).
- Loosen and remove eight screws (26) on the upper flange of the post insulator.
- Carefully lift the interrupter chamber 60-80 mm. This will result in a gap (G) between the interrupter chamber and the upper flange of the post insulator.

---

 **WARNING**

Do not reach into this gap (G) with your hand.

**Therefore:**

- **Always use a tool to remove the coupling pin connection.**

- 
- Remove the splint pin (25) using tool T114.
  - Remove the coupling pin (24) using tool T115.
  - Lift off the interrupter chamber and fasten in to a suitable fixture with four M16 screws. Use the holes in the lower high voltage terminal pads for this purpose.

---

**CAUTION**

Lifting the interrupter chamber more than 80 mm may damage the components.

**Therefore:**

- **Do not lift the interrupter chamber more than 80 mm.**
-

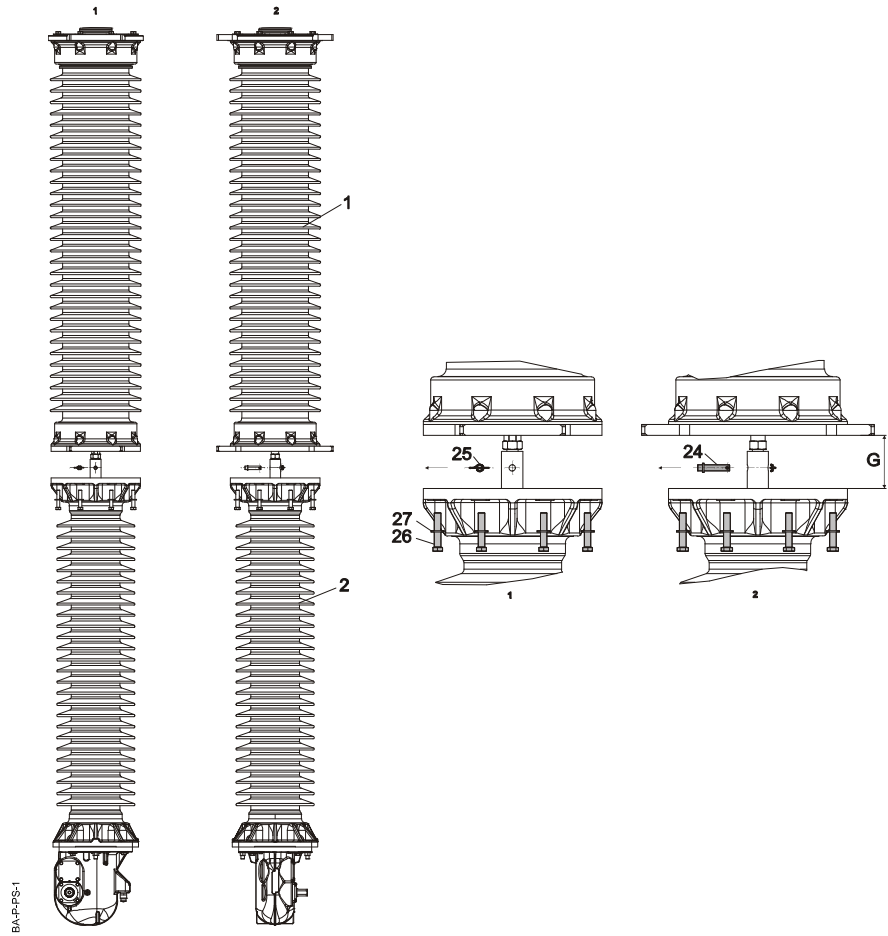

1	Interrupter chamber	1x
2	Upper flange of post insulator	1x
24	Coupling pin	1x
25	Splint pin 12KK2000 964	1x
26	Hexagon screw, M12x65 A2-70	8x
27	Washer, 12 A2	8x
G	Max. gap 80 mm	-

## 10.1.2 Removing the Double Motion System

- Remove eight screws (3) and washers (4) from the upper flange of the chamber insulator (1).
- Carefully remove the double motion system (2).

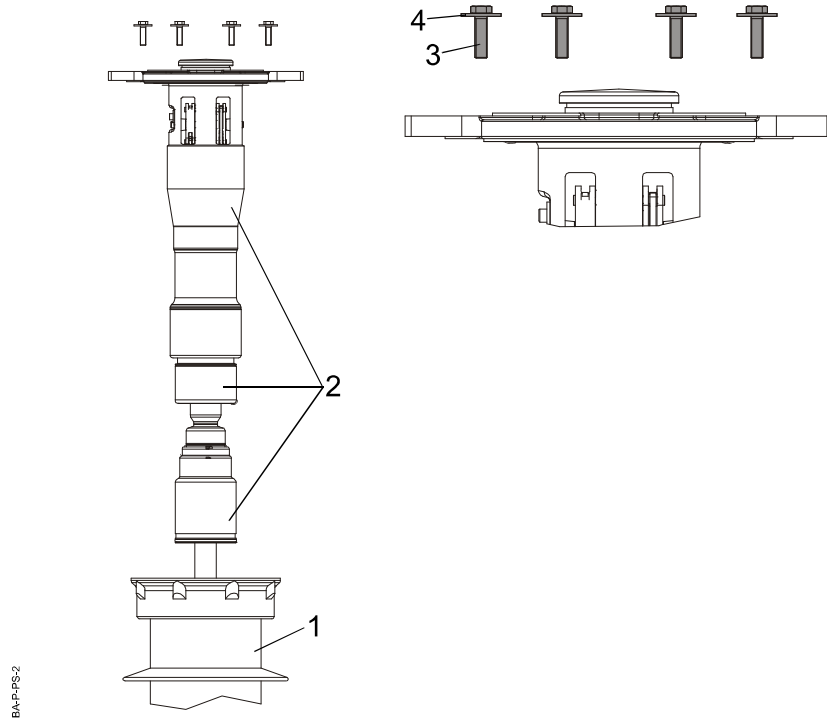

1	Chamber insulator	1x
2	Double motion system	1x
3	Hexagon screw, M12x45 A2-70	8x
4	Washer, 12x40 A2	8x

10.1.3 Removing the Guide Shaft

**CAUTION**

“Switchgear with 4031” on page 85  
 “Switchgear with 4040” on page 86

10.1.3.1 Switchgear with 4031

- Remove the socket head cap screw (17) and the locking plate (18).
- Remove the guide shaft (28) and space sleeve (21) from the fixed contact.
- The interrupter unit is connected by the guide lever to the movable contact system. Remove the interrupter unit, the guide lever and the movable contact system from the fixed contact.

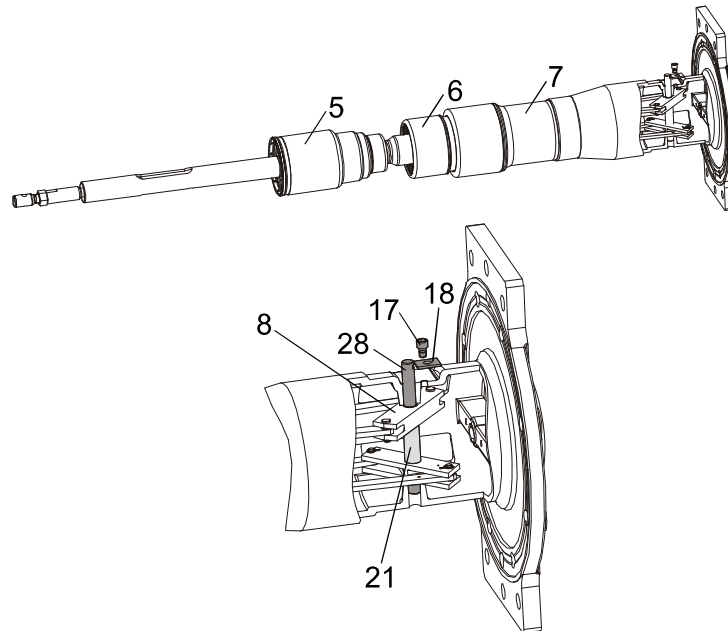

BA-P-PS-3

5	Interrupter unit	1x
6	Movable contact system	1x
7	Fixed contact	1x
8	Guide lever	2x
17	Socket head cap screw, M8x12 A-70	1x
18	Locking plate	1x
21	Spacer sleeve	1x
28	Guide shaft	1x

## 10.1.3.2 Switchgear with 4040

- Remove circlip (81) with tool T122.
- Remove the guide shaft (80) and space sleeve (21) from the fixed contact.
- The interrupter unit is connected by the guide lever to the movable contact system. Remove the interrupter unit, the guide lever and the movable contact system from the fixed contact.

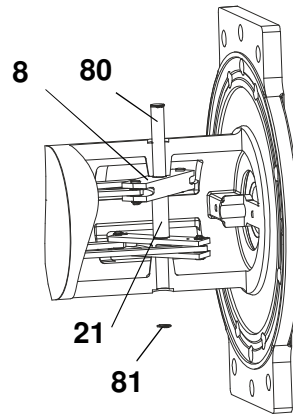
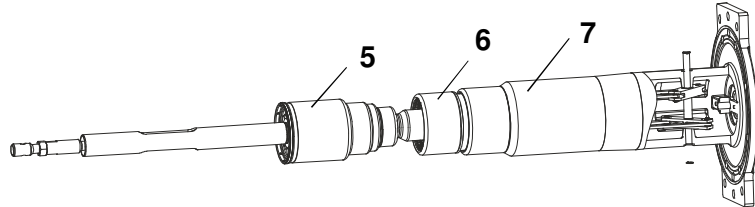

4040A Umfichtschere ausbauen

5	Interrupter unit	1x
6	Movable contact system	1x
7	Fixed contact	1x
8	Guide lever	2x
21	Spacer sleeve	1x
80	Guide shaft	1x
81	Circlip DIN 471 14x1 A2	2x

10.1.4 Disconnecting the Making and Breaking Units

- Remove the cotter pins (10) and flanged coupling pins (9) from the two guide levers. We recommend tool T101 for removing the cotter pins.
- Pull the interrupter unit out of the movable contact system.

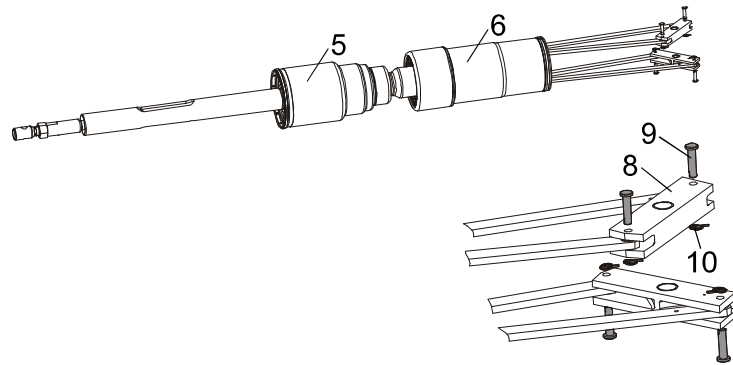

BA-P-PS-4

5	Interrupter unit	1x
6	Movable contact system	1x
8	Guide lever	2x
9	Flanged coupling pin, 6x24	4x
10	Cotter pin, 8x1.2	4x

10.1.5 Reconditioning the Movable Contact System

- Replace the arcing contact pin (29). Lubricate the contact surfaces per lubrication specification L6. Tighten the screw (30) to a torque of 17Nm.
- Replace the guide strip (11). The guide strip is located in a dovetail groove. It is therefore necessary to overcome mechanical resistance when replacing it.
- Lubricate the outer diameter of the movable contact system in the area of the electrical sliding contact surface per lubrication specification L6.

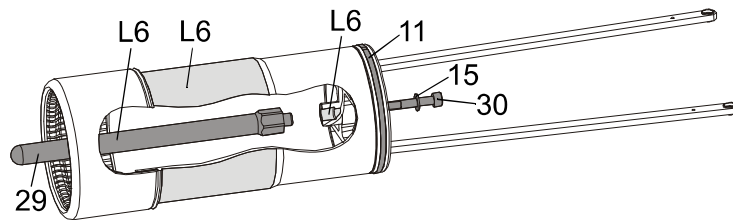

BA-P-PS-5

11	Guide strip 3x5x398	1x
15	Washer, 8 A2-70	1x
29	Arcing contact pin	1x
30	Socket head cap screw, M8x20 A-70	1x

## 10.1.6 Reconditioning the Fixed Contact

- Replace the guide strip (12). The guide strip is located in a dovetail groove. It is therefore necessary to overcome mechanical resistance when replacing it.

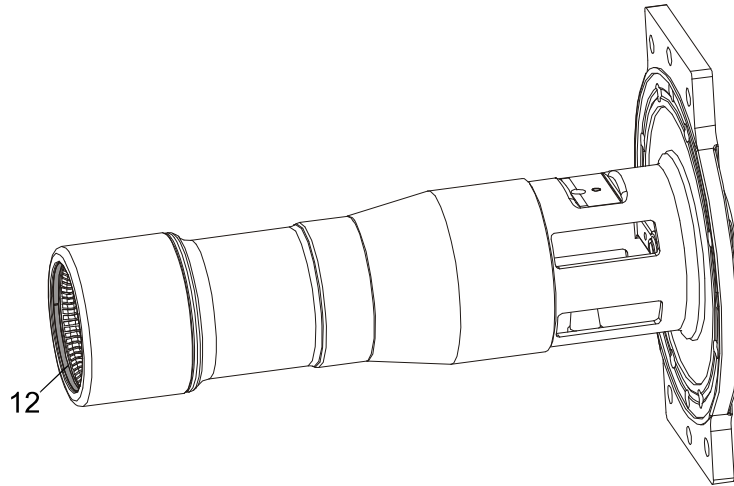

BA-P-PS-6

12	Guide strip, 3x5x380 (GK)	1x
----	---------------------------	----

## 10.1.7 Lubricating the Interrupter Unit

- Unpack and grease a new interrupter unit (5).
  - Lubricate the outer diameter of the interrupter unit in the area of the electrical sliding contact surface per lubrication specification L6.
  - Grease the entire length of the interrupter tube in the interrupter unit per lubrication specification L7.

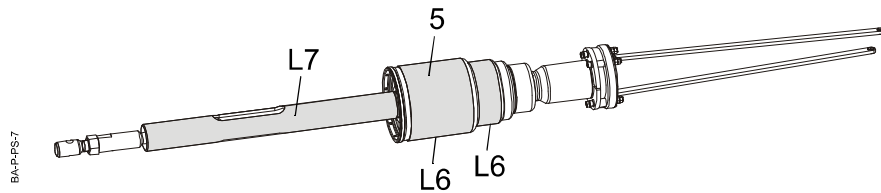

BA-P-PS-7

5	Interrupter unit	1x
---	------------------	----



10.1.8 Connecting the Making and Breaking Units

The two lever arms of the guide lever are not identical. Matching them up with the guide rods is facilitated by an identification system.

Identification System

	Guide lever	Guide rod
Movable contact system	Dot mark	Dot mark
Interrupter unit	No dot mark	No dot mark

- Insert a new interrupter unit into the movable contact system until it hits the stop. As you do so, insert the rods of the interrupter unit through the large holes in the movable contact system.
- Lubricate new flanged coupling pins (9) per lubrication specification L7.
- Insert the rods of the movable contact system into the guide levers, selecting the lever arm **marked with a dot**.
- Insert the rods of the interrupter unit into the guide levers, selecting the lever arm that is **not marked with a dot**.
- Insert a new flanged coupling pin (9) from the outside into the rods and levers.
- Secure it with a new cotter pin (10). We recommend tool T101 for installing the cotter pins.

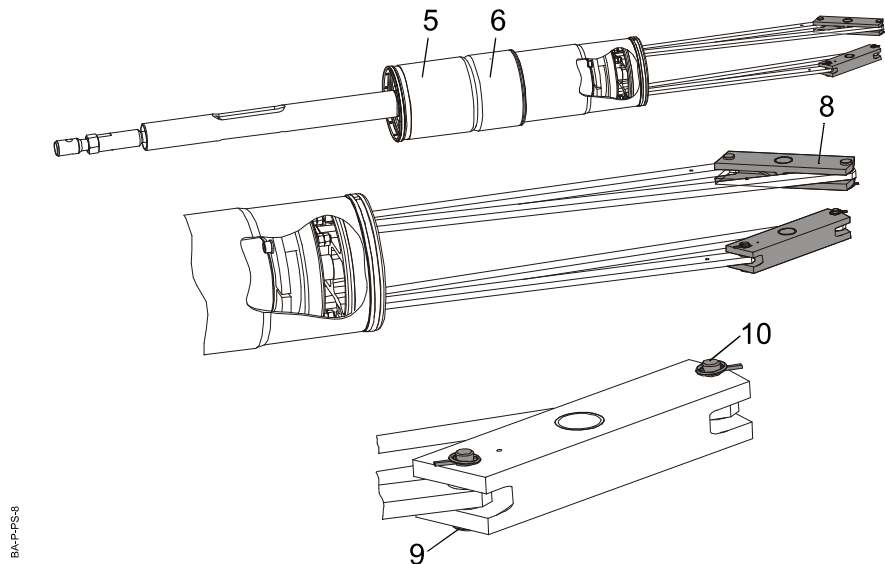

5	Interrupter unit	1x
6	Movable contact system	1x
8	Guide lever	2x
9	Flanged coupling pin, 6x24	4x
10	Cotter pin, 8x1.2	4x

**CAUTION**

The two lever arms of the guide lever are not identical. Mismatching of rods and levers can result in damage to the pole columns.

**Therefore:**

- **Make sure you have correctly matched the rods and levers.**
  - **The lever arm for the double motion unit and the rod of the double motion unit are marked with dots.**
  - **The lever arm for the interrupter unit and the rod of the interrupter unit have no dot mark.**
-

10.1.9 Mounting the Guide Shaft

**CAUTION**

“Switchgear with 4031” on page 85  
 “Switchgear with 4040” on page 92

10.1.9.1 Switchgear with 4031

- Insert the interrupter unit (5) and the movable contact system (6) into the fixed contact (7) so that the shaft holes in the guide levers (8) and fixed contact (7) are lined up.
- Place the spacer sleeve (21) between the levers.
- Connect the guide lever and fixed contact to the guide shaft (28).
- Coat a new screw (22) with locking adhesive per S1.
- Fasten the shaft with the locking plate (23) and the new screw (22). Tighten to a torque of 17Nm.

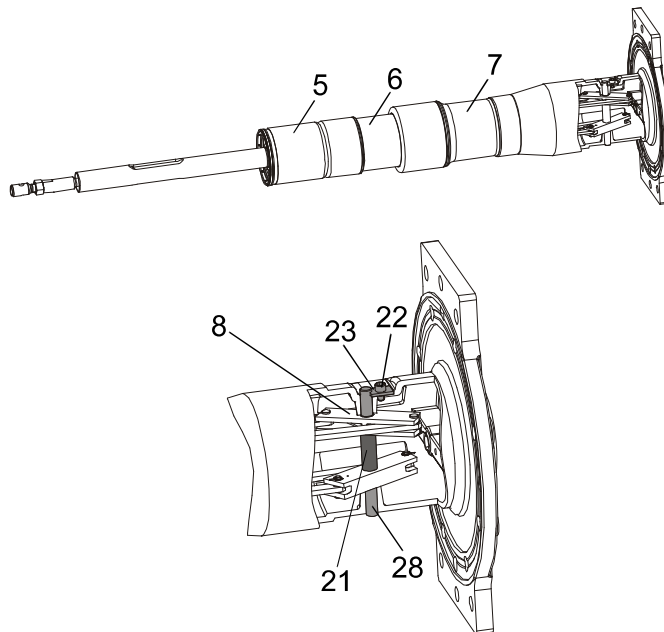

BW-PPS-9

5	Interrupter unit	1x
6	Movable contact system	1x
7	Fixed contact	1x
8	Guide lever	2x
17	Socket head cap screw, M8x12 A2-70	1x
21	Spacer sleeve	1x
23	Locking plate	1x
28	Guide shaft	1x

## 10.1.9.2 Switchgear with 4040

- Insert the interrupter unit (5) and the movable contact system (6) into the fixed contact (7) so that the shaft holes in the guide levers (8) and fixed contact (7) are lined up.
- Place the spacer sleeve (21) between the levers.
- Connect the guide lever and fixed contact to the guide shaft (80).
- After inserting the axis, install the new circlip (82) in the groove with tool T122.
- During installation, ensure that the circlip is not over-spread (plastic deformation).

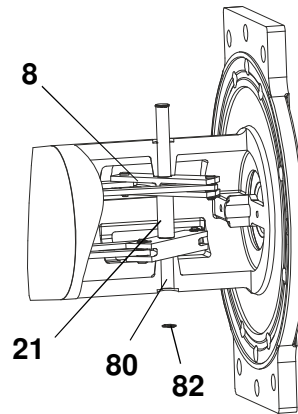
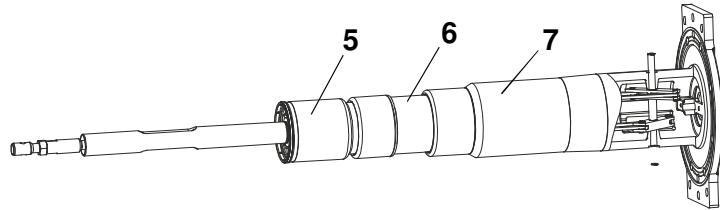

mehrfache montieren

5	Interrupter unit	1x
6	Movable contact system	1x
7	Fixed contact	1x
8	Guide lever	2x
21	Spacer sleeve	1x
80	Guide shaft	1x
82	Circlip DIN 471 14x1 A2	2x

10.1.10 Reconditioning the Holder

- Attach lifting tackle to the upper flange of the chamber insulator.
  - Loosen and remove two screws (17) on the lower flange of the chamber insulator (1).
  - Lift up the chamber insulator.
  - Replace the two guide strips (18). The guide strips are located in dovetail grooves. It is therefore necessary to overcome mechanical resistance when replacing it.
  - Clean the sealing and flange surfaces of the holder (16) and grease them per lubrication specification L3.
  - Replace the formed gasket (19).
  - Lubricate two screws (17) per L1.
  - Replace the chamber insulator and fasten it with two screws (17). Tighten to a torque of 17Nm.
- Fill the counterbores in the holder completely with grease per L3.

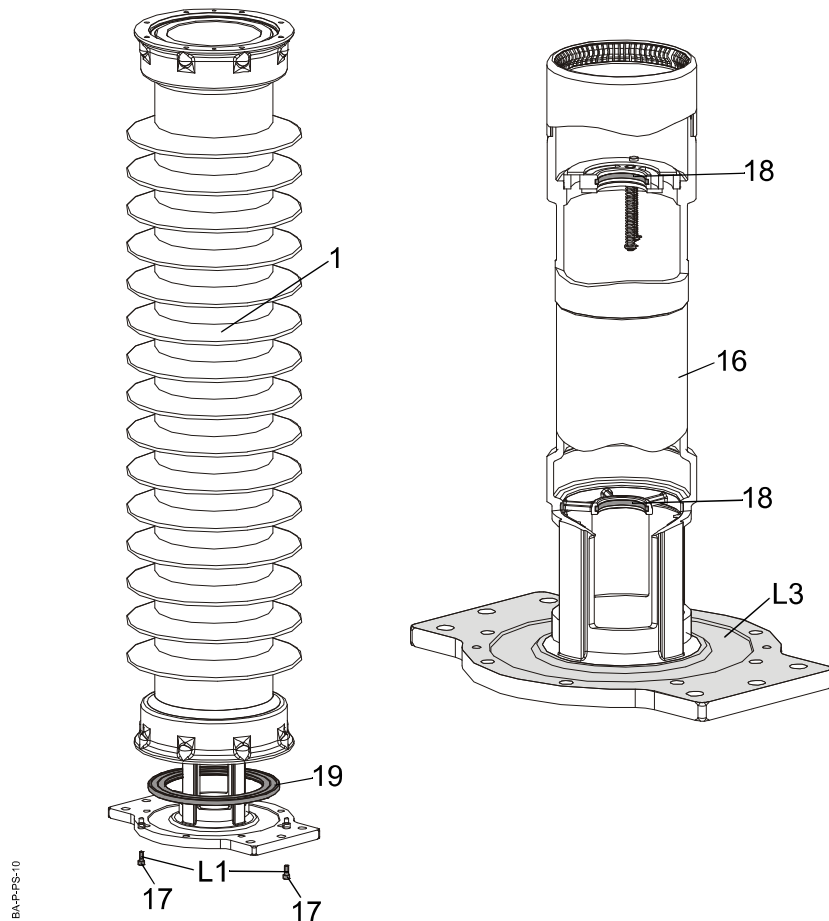

1	Chamber insulator	1x
16	Holder	1x
17	Socket head cap screw, M8x20 A-70	2x
18	Guide strip, 3x5x146	2x
19	Formed gasket 271	1x

### 10.1.11 Installing the Double Motion System

- Clean the sealing and flange surfaces of the fixed contact (7) and grease them per lubrication specification L3.
- Replace the formed gasket (19).
- Move guide tool T102 above the connecting rods of the interrupter unit (5) and insert it into the interrupter tube. The guide tool is held in the interrupter tube by its O-rings.
- Lift the double motion system (2) above the chamber insulator and align it coaxially.
- Carefully insert the double motion system into the holder using guide tool T102. When inserting the interrupter unit into the contact system in the holder, an additional resistance must be overcome.
- Fasten the double motion system to the chamber insulator using eight screws (3) and eight washers (4)
- Remove the guide tool (pull it down and out).

---

**CAUTION**

Improper installation may result in damage to the insulator or the guide strips.

**Therefore:**

- **Never install the double motion system without using the guide tool.**
-

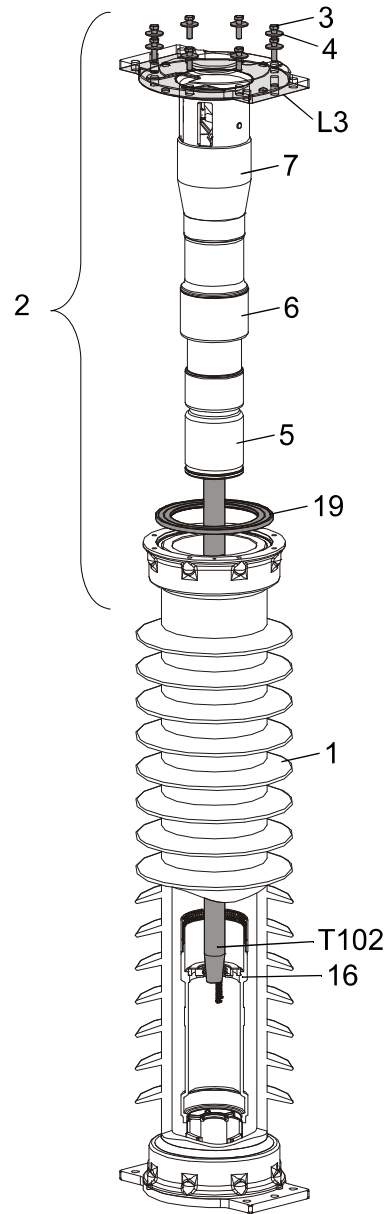

BA-PFS-11

1	Chamber insulator	1x
2	Double motion system	1x
3	Hexagon screw, M12x45 A2-70	8x
4	Washer, 12x40 A2	8x
5	Interrupter unit	1x
6	Movable contact system	1x
7	Fixed contact	1x
16	Holder	1x
19	Formed gasket 271	1x

## 10.1.12 Adjusting the Double Motion System

- Pull the interrupter unit down until it touches the stop (required tensile force approx. 200N).
- Align the flattened sides of the connecting rod (31) so that they are parallel with the high voltage terminal pads (32). Alignment is accomplished by turning the interrupter unit.
- Adjust the distance between the lower edge of the holder (16) and the center of the hole in the coupling piece (33) to  $69.5\pm 1\text{mm}$ . The hole in the coupling piece (33) and the flattened sides of the connecting rod must be aligned in the direction of the high voltage terminal pads.
- Tighten the nut (34). Tighten to a torque of 130Nm.

### CAUTION

Improper adjustment of the interrupter unit can result in damage during operation.

**Therefore:**

**Carefully adjust and check the following:**

- **Distance of  $69.5\pm 1\text{mm}$ .**
- **Alignment of the flattened connecting rod side.**
- **Alignment of the hole in the coupling piece.**

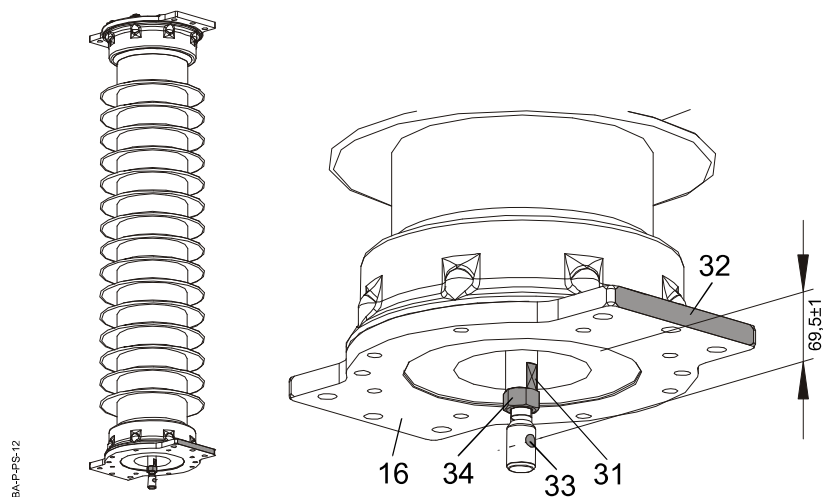

31	Connecting rod	1x
32	High voltage terminal pad	1x
33	Coupling piece	1x
34	Hexagon nut, M20x1.5 A2-70	1x



### 10.1.13 Connecting the Interrupter Chamber to the Post Insulator

The insulating tube in the post insulator must be in the closed position for this procedure.

- Clean the sealing and flange surfaces of the holder (16) and grease them per lubrication specification L3.
- Replace the gasket (35).
- Lift the interrupter chamber and position it above the post insulator.
- Carefully lower the interrupter chamber and insert the coupling piece (33) into the insulating tube (38) until the holes in the coupling piece and insulating tube are aligned.
- Lubricate new coupling pin per lubrication specification L7.



Do not reach into this gap (G) with your hand.

**Therefore:**

- **Always use a tool to remove the coupling pin connection.**

- 
- Connect the interrupter chamber and insulating tube with the new coupling pin (24), using tool T115 and secure it with the new splint pin (25), using tool T114.
  - Coat the screws (26) as per L1.
  - Lower the entire interrupter chamber on to the post insulator and fasten it using eight screws (26). Tighten to a torque of 83Nm.

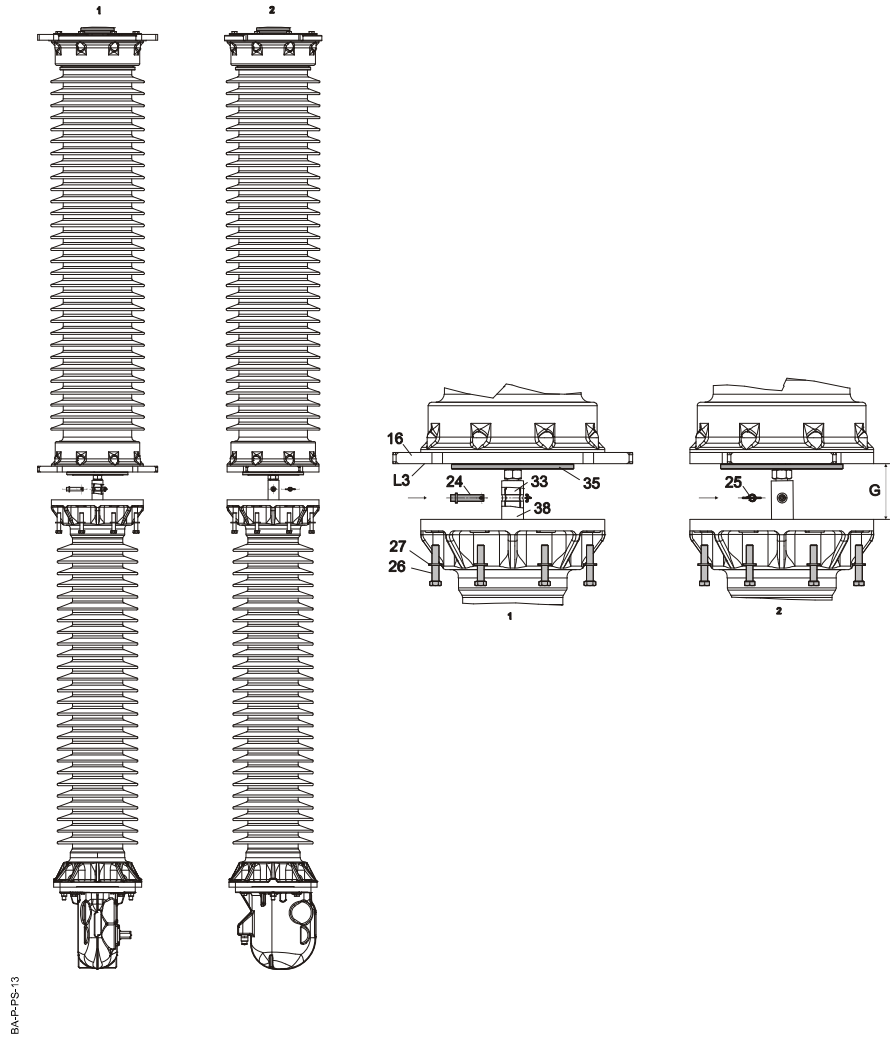

16	Holder	1x
24	coupling pin	1x
25	splint pin 12KK2000 964	1x
26	Hexagon screw, M12x65 A2-70	8x
27	Washer, 12 A2	8x
33	Coupling piece	1x
35	Formed gasket 221	1x
38	Insulating tube	1x

10.1.14 Replacing the Adsorption filter

In some cases, levers of the circuit breaker linkage may cover or conceal the filter cover. If this is the case, the levers must be removed and remounted after the adsorption filter is replaced.

- Remove the four screws (62) and the filter cover (47).
- Remove the filter sleeve (48) and filter bag (65) from the crankcase (37).
- Lubricate the sealing areas per L5.
- Replace the O-ring (59). Before installation, lubricate it per L5.
- Insert a new filter bag in the filter sleeve and slide both into the crankcase.
- Coat the screws (62) as per L1.
- Replace the filter cover and fasten it with four screws (62). Tighten to a torque of 7Nm.

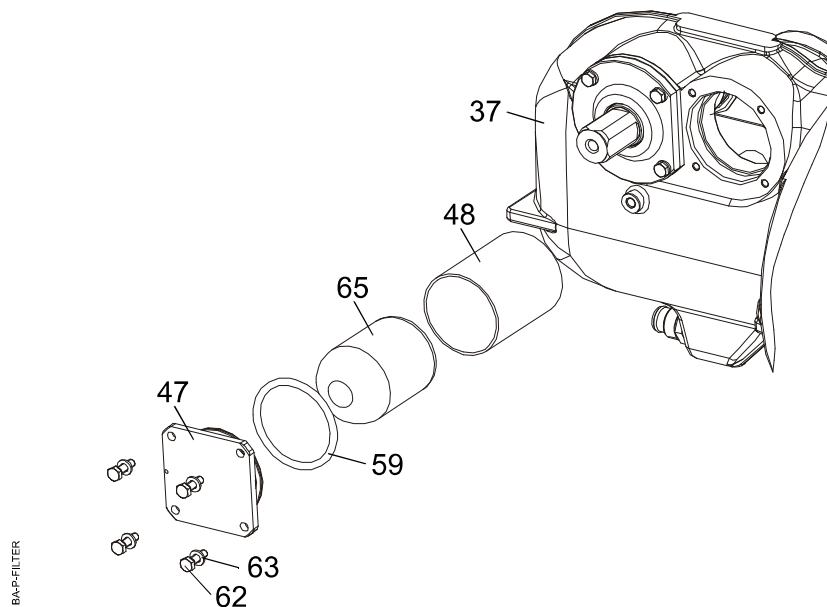

37	Crankcase	1x
47	Filter cover	1x
48	Filter sleeve	1x
59	O-ring, 62.87x5.33	1x
62	Hexagon screw, M6x20 A2-70	4x
63	Washer, 6 A2	4x
65	Filter bag	1x

## 10.1.15 Final Operations

- Evacuate the breaker.
- Fill the breaker with gas and check all seals for leakage (**see “Filling the Breaker with Gas” on Page 56**).

## 10.2 Disassembling the Post Insulator and Crankcase

### Requirements

- The interrupter chamber has already been disconnected from the post insulator.
- The levers of the circuit breaker linkage have been removed.
- Fasten the lifting tackle to the upper flange of the post insulator and hook the tackle in the crane hook.
- Detach the post insulator from the base frame.
- Carefully lift the post insulator and crankcase assembly up out of the base frame and set it down on a suitable work surface.
- Remove four bolts (67) and two nuts (66) from the crankcase mounting system.
- Pull the crankcase and insulating rod out of the post insulator.
- Reverse the sequence to assemble the components. In the process, replace the gasket (35).

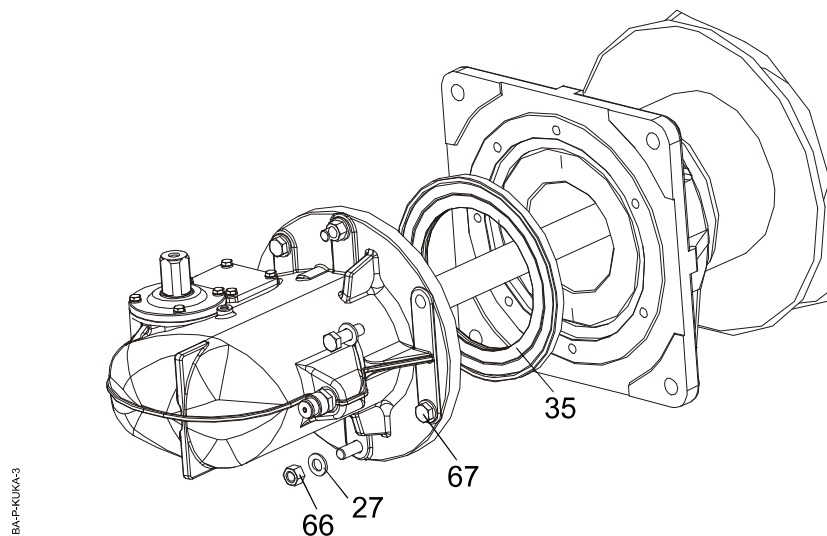

27	Washer, 12 A2	6x
35	Formed gasket 221	1x
66	Hexagon nut, M12 A2-70	2x
67	Hexagon bolt, M12x40 A2-70	4x

10.2.1 Disassembling the Opening Springs

- Remove the filter cover. Remove the filter sleeve (48) and filter bag (65) from the crankcase.
- Loosen the three screws (68). To do so, loosen the screws gradually one by one in order to prevent the spring guide (69) from tilting.
- Remove the spring guide (69) and opening spring (70) from the crankcase and carefully pull them off the insulating tube (38).

Reverse the sequence to install the components. Tighten the screws to a torque of 17Nm. Before remounting the screws, lubricate them per L1.

**In the open state, the precharging travel of the opening spring is shorter than the thread engagement length of the screws (68). The screws are therefore used as a releasing and charging device for the opening springs.**

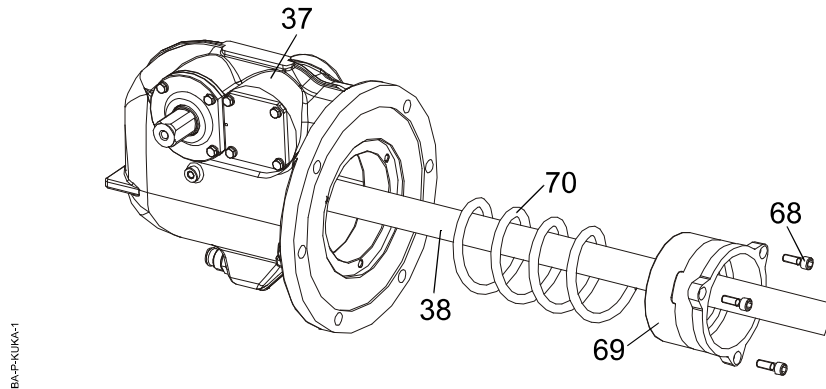

37	Crankcase	1x
38	Insulating tube	1x
68	Socket head cap screw, M8x25 A2-70	3x
69	Spring guide	1x
70	Opening spring	1x

## 10.2.2 Disassembling the Crankcase

- Remove the four screws (64) and the bearing cap (44).
- Remove the bearing insert (45) and the outer part of the cylindrical roller bearing.
- Remove the shaft (43) and inner ring from the cylindrical roller bearing.
- Remove the insulating tube (38) along with the inner lever (40) and spring seat (41) from the crankcase.

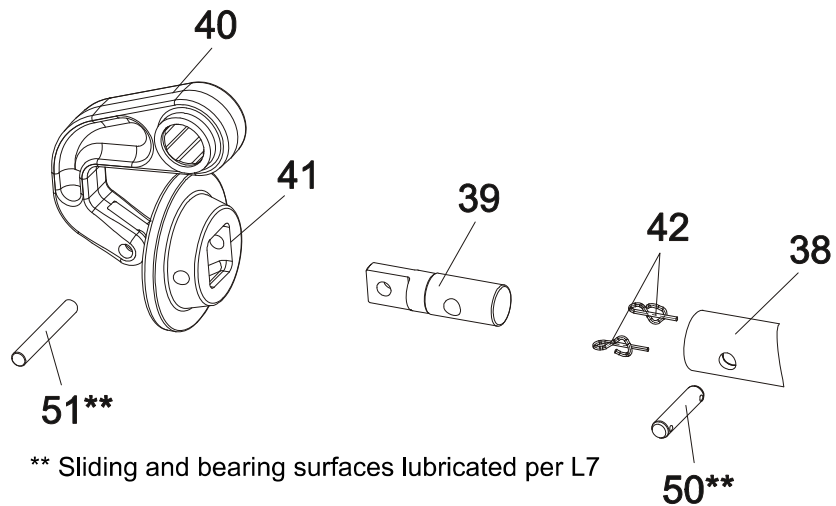

37	Crankcase	1x	52	Roller bearing	1x
38	Insulating tube	1x	53	Roller bearing	1x
39	Connecting piece, bottom	1x	54	Axial needle roller assembly	1x
40	Inner lever	1x	55	Axial ring	1x
41	Spring seat	1x	56	Bearing ring	1x
42	splint pin 12KK2000 964	2x	57	Sealing ring	1x
43	Shaft	1x	58	O-ring 34.52x3.53	1x
44	Bearing cap	1x	59	O-ring, 62.87x5.33	2x
45	Bearing insert	1x	60	O-ring 38.82x5.33	2x
46	Bearing sleeve	1x	62	Hexagon screw, 6x20 A2-70	4x
47	Filter cover	1x	63	Washer, 6 A2	8x
48	Filter sleeve	1x	64	Hexagon screw, 6x25 A2-70	4x
50	Pin, 12x47.5	1x	65	Filter bag	1x
51	Pin, 10x75	1x			

**Reassembly:**

- Replace all O-rings and gaskets.
- Reverse the sequence to assemble the crankcase.
- Insert a new filter bag (*see “Replacing the Adsorption filter” on Page 99*).

---

**CAUTION**

The following instructions must be followed when assembling and installing the parts:

- Follow the specified lubrication procedure.
- Replace all seals and gaskets.
- Tighten the three screws (68) to a torque of 18Nm.
- Do not forget the filter sleeve (48).
- Do not install a new filter bag until right before evacuating the assembled pole column.

- 
- Mount the interrupter chamber (*see “Connecting the Interrupter Chamber to the Post Insulator” on Page 97*).
  - Remount the pole column on the base frame.
  - Re-commission the circuit breaker as described in the commissioning section.





## 11 End-of-Life Management

Environmentally compatible waste management is an integral part of the overall design of GE products. Eco-friendly waste handling in accordance with applicable regulations is guaranteed.

When it comes to waste management, recycling of materials is generally preferred to disposal.

Materials can be recycled as mixed scrap or - in cases where equipment is largely disassembled - as sorted scrap with a small residual amount of mixed scrap.

Sorted scrap is the preferred waste management option.

Switchgear has the following components:

- Ceramics / silicone
- Steel
- Aluminum
- Copper
- PTFE (polytetrafluoroethylene)
- Casting resin (some of which is fabric-reinforced)
- Rubber materials used as seals and gaskets
- Plastics in the operating mechanism (auxiliary switches, cable insulation, etc.)
- Hydraulic fluid
- Lubricants in small amounts

Waste management procedures must ensure that hydraulic fluids present in mechanism dampers are drained off. Compliance with regulations governing management of these wastes is required.

None of the oils and greases used in the switchgear contain PCBs (polychlorinated biphenyls).

No hazardous substances covered by the German regulations governing hazardous materials are present in the switchgear in as-delivered condition. For export purposes, compliance with local laws and regulations must be ensured.

The gas used for insulation and quenching is to be drawn off using suitable equipment and reused after reprocessing.

Solid decomposition products generated by operations may be present in the gas compartments. These products may constitute a health hazard if the gas compartments are opened.

Gaseous decomposition products are collected by filters. Compliance with the appropriate safety rules (*see "Safety Precautions When Handling Used SF<sub>6</sub>" on Page 17*) is required.

Your local GE Service will be happy to answer any questions you may have about waste management.



---

## **12 Special Equipment (Optional)**

---

This chapter describes only special equipment that is not part of the standard equipment of the switchgear. Special equipment is only available as option.

---

### **12.1 EasyCheck Density Monitor Unit**

bs-246-hs-205/511-02

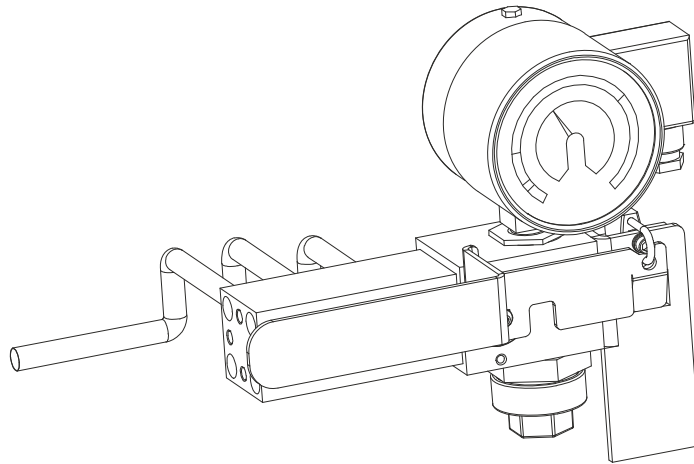

---

The EasyCheck technology makes it particularly easy to perform the emission-free density monitor test in correspondence with the "F-gases regulation EU 517/2014" quickly and safely.

---

## SPECIAL EQUIPMENT (OPTIONAL)

### 12.1.1 Functional description

The EasyCheck density monitor unit is equipped with an additional shut-off valve that permits separation of the pole column gas compartments (G1) from the gas compartment of the density monitor and the central filling connection (G2) without loosening couplings or screws. This will achieve best error avoidance and recommissioning safety.

The valve is actuated via a lever that covers the greatest part of the density monitor dial in the test position. Thus, the valve position can be recognised even from a long distance, and unmonitored operation of the circuit breaker in the test position can be recognised and avoided.

- For movement of the lever from the position "Operation" to the position "Test", the right hand must be used to unlock the automatic latching tab while the left hand at the same time moves the lever clockwise by 90°. This two-hand operation prevents accidental shifting of the lever from the position Operation to the position Test.

Additionally, the valve can be secured against unauthorised actuation in the position Operation.

Figure Pneumatic plan:

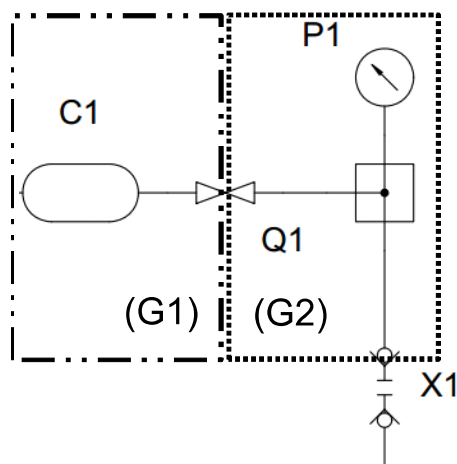

Element	Description
(G1)	Gas compartment 1
(G2)	Gas compartment 2
C1	C1 gas volume of the switchgear
Q1	Shut-off valve "EasyCheck"
P1	Manometer
X1	Central filling coupling (DILO)

### 12.1.2 Operating condition

The shut-off valve Q1 is open, the gas compartments (G1) and (G2) are connected to each other. The density monitor P1 monitors the gas in the switchgear gas compartments. The central fill coupling (X1) permits filling of the switchgear with gas or extraction of gas.

The actuation lever (H) is placed horizontally.  
The operating condition is secured against accidental damage by the latch (R).

The bore (PL) permits switch position securing by a padlock (VHS).

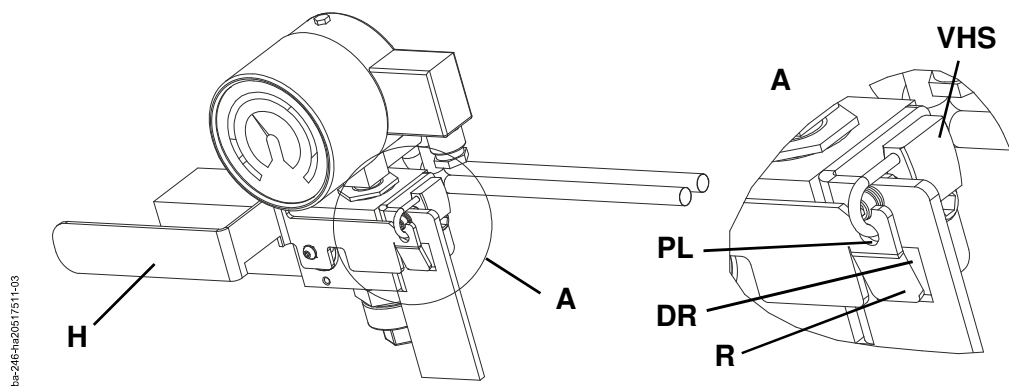

## SPECIAL EQUIPMENT (OPTIONAL)

---

### 12.1.3 Test condition

The shut-off valve Q1 is closed, the gas compartments (G1) and (G2) are disconnected from each other.

The density monitor P1 monitors only the gas pressure in the volume G2, but not the gas pressure in the switchgear gas compartments.

The actuation lever (H) is placed vertically.

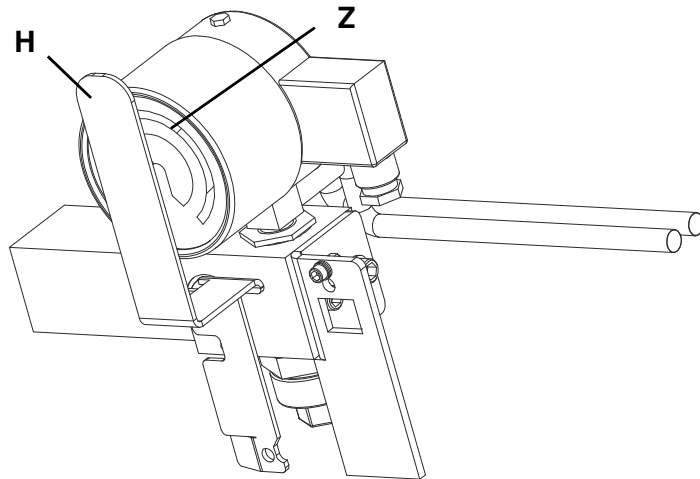

ba-246-02051751-04

The central fill coupling (X1) can be used to change the gas pressure in the volume G2 and check the display as well as the switching points of the density monitor without influencing the gas pressure in the switchgear gas compartments.

For this, a suitable test facility (e.g. SF<sub>6</sub>-multi analyser by DILO) must be used that collects the escaping gas.

In the test condition, the density monitor can be exchanged as well without emitting any gas to the environment.

In the test condition, the dial of the density monitor is covered to the greatest part.

When the lever is returned to the position "Operation", it will latch on its own.

**12.2 FlexLink-Gas Connection**

The FlexLink technology makes it particularly easy to couple the gas connections to the pole columns.

The FlexLink gas connections consist of metal corrugated tubes that are elastic to ensure that the connection of the gas couplings to the pole columns is particularly easily possible. The gas connections are firmly connected to the density monitor unit on one side. The other side has a filling coupling with check valve for connection to the pole columns. FlexLink is available for the standard density monitor unit as well as for the EasyCheck technology.

**12.2.1 Setup of the FlexLink-Gas Connction**

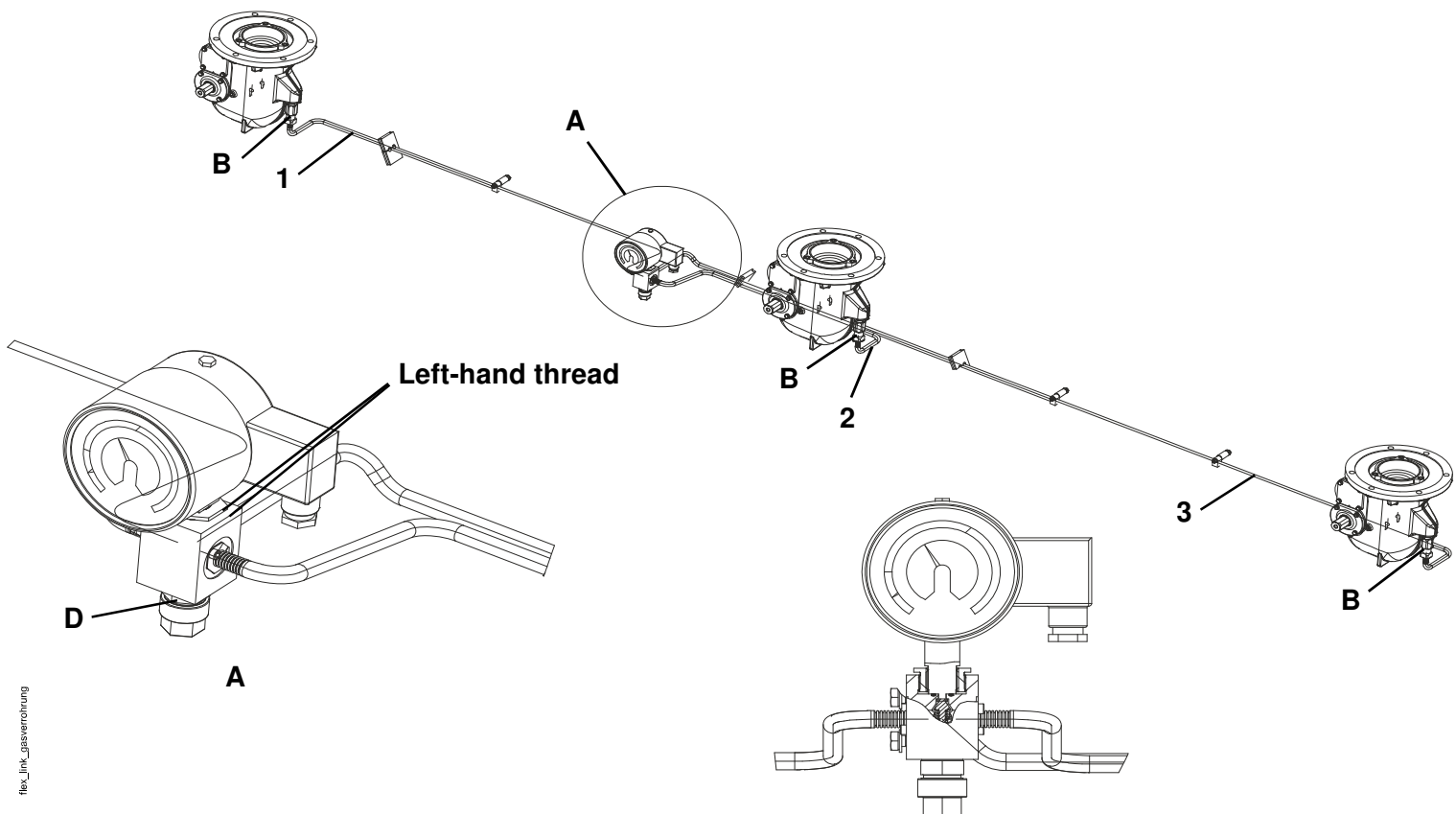

<b>1</b>	FlexLink gas piping pole A	1x
<b>2</b>	FlexLink gas piping pole B	1x
<b>3</b>	FlexLink gas piping pole C	1x
<b>4</b>	Density monitor	1x
<b>B</b>	Gas pipe / filler coupling	30 Nm
<b>D</b>	Central fill connection / filler block	30 Nm
<b>E</b>	Threaded sleeve / filler block	30 Nm Left-hand thread

## SPECIAL EQUIPMENT (OPTIONAL)

---

### 12.2.2 If FlexLink Gas Piping Is Already Installed

To check all gas piping seals we recommend the use of the following tools:

- T016: Compact open-end wrench (open-ended spanner), SW24
  - WK001: Torque wrench (spanner) with ratchet adapter and SW27 open-end wrench head
- Retighten filling connections using tool T016 and tool set WK001 to a torque of 30 Nm.
  - Retighten all couplings in the gas piping system.

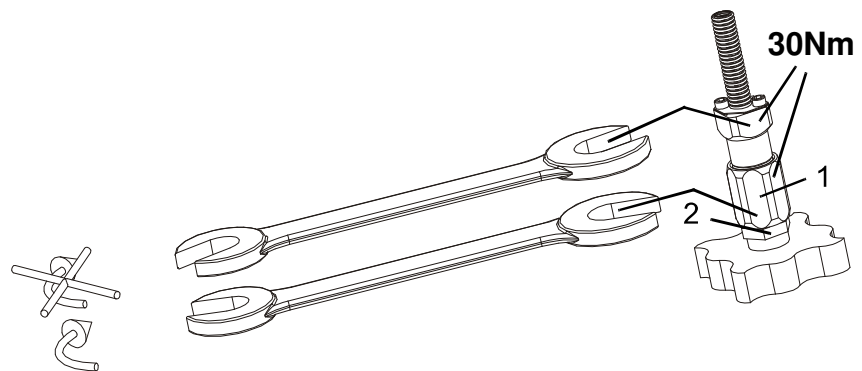

1	Union nut	1x
2	Valve	1x



**12.2.3 FlexLink Gas Piping Still Needs To Be Installed**

To check all gas piping seals we recommend the use of the following tools:

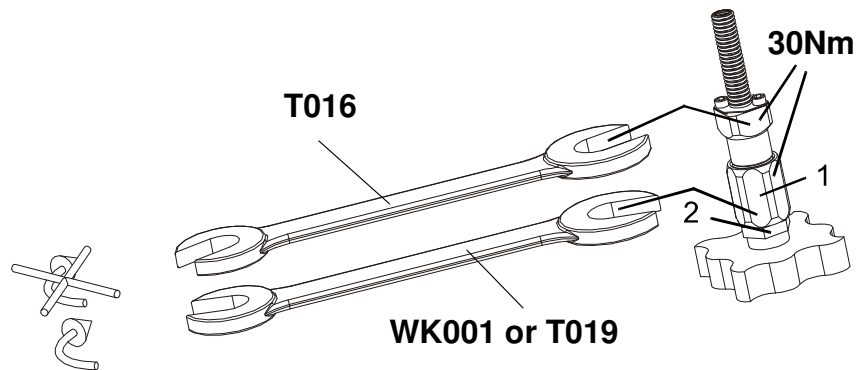

- T016: Compact open-end wrench (open-ended spanner), SW24
- WK001: Torque wrench (spanner) with ratchet adapter and SW27 open-end wrench head
- 
- Remove the protective caps from the gas couplings on the pole columns and the gas piping.
- Lubricate the threads of the gas couplings as per L4.
- Connect the gas piping to all pole columns. The gas couplings are equipped with threads for this purpose. First screw on the gas couplings by hand, then tighten them provisionally using tool T016, and finally tighten them using tool set WK001. Tighten to a torque of 30 Nm.
- Retighten all couplings in the gas piping system.

---

We recommend that the gas cylinder be weighed before and after the filling operation and that the weight difference be compared with the gas weight specified on the nameplate. This makes it possible to verify that the filling process has been carried out correctly.

---

## SPECIAL EQUIPMENT (OPTIONAL)

### 12.2.4 Exchange of FlexLink Gas Connections

The flexible metal hose is fitted for sealing purposes with a sealing set consisting of a plastic bushing (1.1) flanked by two O-rings (1.2). For the sealing set to fit properly on the end of the flexible metal hose (1), two corrugation valleys (2) must remain uncovered. Two locking plates (3) offset radially from one another prevent the sealing set from sliding when inserted into the sealing area of the coupling (4). A secure fit of the flexible metal hose (1) is ensured by screwing on the locking plates (3).

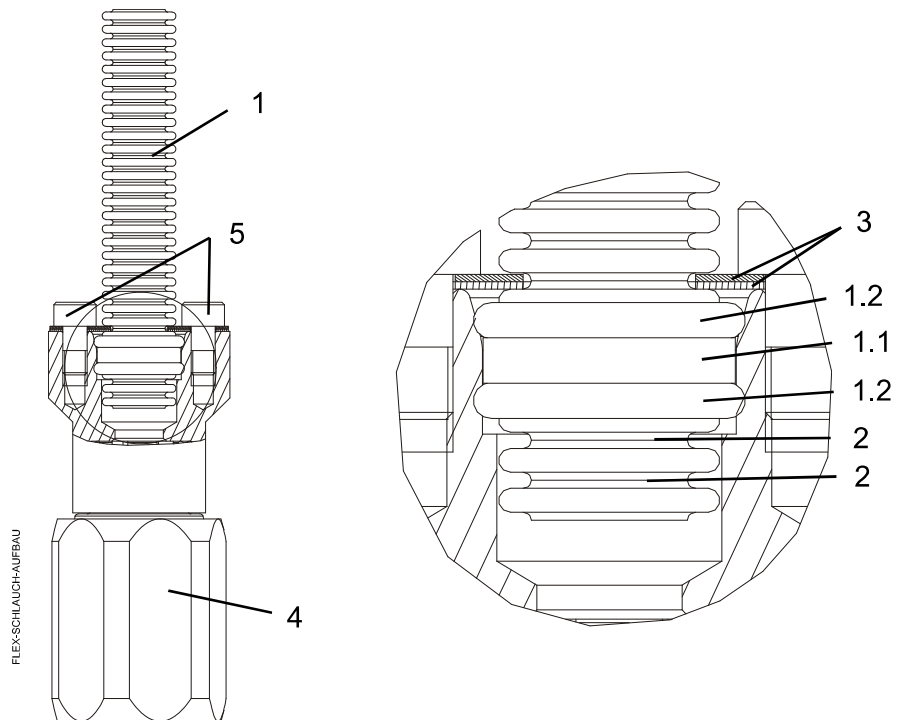

<b>1</b>	Flexible metal hose	1x
<b>1.1</b>	Plastic bushing	1x
<b>1.2</b>	O-ring	2x
<b>2</b>	Corrugation valley	-
<b>3</b>	Locking plate	2x
<b>4</b>	Coupling (filling connection)	1x
<b>5</b>	Screw	2x

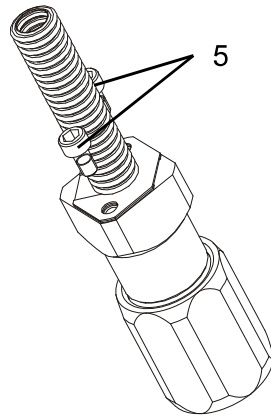

diagram 1

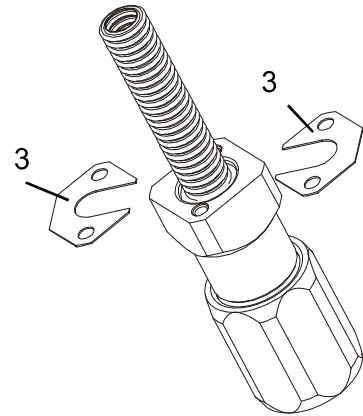

diagram 2

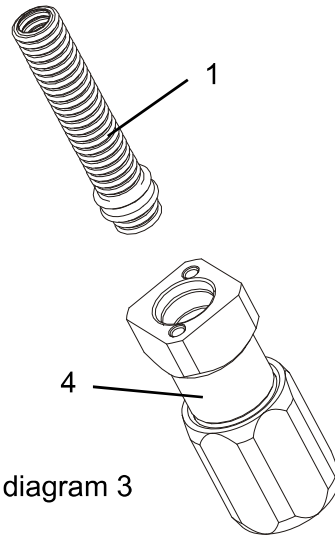

diagram 3

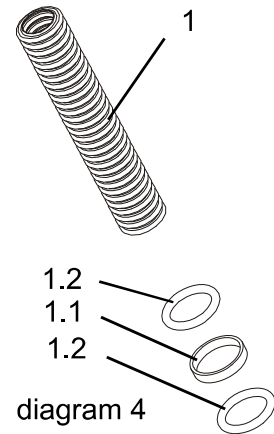

diagram 4

FLEX-SCHLAUCH-DEMONTAGE

- Disconnect the gas coupling. This will disconnect the gas compartments of the poles from the gas piping.
  - Unscrew the screws (5) (see diagram 1).
  - Push the locking plates (2) to one side (diagram 2)
  - Carefully pull the metal hose (1) out of the coupling (4) (diagram 3).
  - Apply lubricant to two new O-rings (1.2) as per L5, and slide the O-rings and the plastic bushing (1.1) onto the new flexible metal hose (1) past the first two corrugation valleys (2), leaving the latter uncovered.
  - Apply lubricant to the sealing areas on the flexible metal hose (1) and the coupling (4) as per L5.
  - Lubricate the threads of the junction points as per L4.
  - Fit the locking plates (3) on opposite sides of the corrugation valley immediately following the O-ring (1.2).
  - Insert the flexible metal hose (1) together with the locking plates (3) into the sealing area of the coupling (4) until the locking plates (3) are in contact with the end of the coupling (4).
- Secure the locking plates (3) with two screws (5) and tighten to a torque of 7 Nm.

**SPECIAL EQUIPMENT (OPTIONAL)**

---

## **A1 Description of the Equipment**

### **A1.1 Purpose**

Circuit breakers are used for power distribution in high voltage networks. They are installed in substations along with other switchgear and are an essential functional and safety feature. In the event of a system disturbance or line fault, circuit breakers interrupt the resulting short-circuit currents within a few milliseconds. These breakers are generally operated by remote control.

### **A1.2 Main Components**

A circuit breaker consists of pole columns, base frame and operating mechanism (*see “Components Supplied” on Page 17*).

Each pole column consists of a post insulator for insulating operational voltage to ground and a chamber insulator in which the interrupter unit is located.

The base frame is a galvanized welded steel structure.

The operating mechanism consists of a steel structure that is self-supporting and protected against corrosion. The door, floor, rear panel, removable side panels, and roof are constructed of aluminum sheet.

### **A1.3 Operation**

The pole columns and the gas piping form a common gas compartment. The movable contacts of the interrupter unit are connected to the operating mechanism by the insulating rods, the torque shafts and levers of the pole column, and the connecting rods in the base frame.

When current is interrupted, the transition from the closed position to the open position occurs within a few milliseconds. During this opening operation, the main contacts separate first. The arc that is formed between the arc contacts that then open is quenched by a gas flow within the interrupter unit. The main contacts, which have already opened, are not eroded by the arc.

In third-generation circuit breakers, the necessary gas pressure is generated in a pressure chamber by the energy of the arc itself as a function of current. The operating mechanism only supplies the energy required for contact movement and mechanical auxiliary blow-out to ensure safe breaking of small currents.

During the closing operation, the arcing contacts are closed first and then the main contacts.

The position is indicated visually by a position indicator.

## **DESCRIPTION OF THE EQUIPMENT**

---

The closing spring in the operating mechanism is charged by an electric motor via a gear unit for the purpose of storing the required operating energy. The main opening springs are located in the pole columns and are thus charged during each closing movement. The spring energy store contains enough mechanical energy to execute the O-CO operation, even if the motor power supply should fail.

Electrical actuation of the closing and opening coils causes latches to be unlatched, which releases the energy of the springs for operating purposes. The spring energy is transferred to the contact system by connecting levers and linkages outside and inside the pole columns.

### **A2 Tools and Auxiliary Equipment**

#### **A2.1 Customer-Supplied Materials and Equipment for Installation and Commissioning**

Customer-supplied materials and equipment are not included in the order or supplied by the manufacturer. They must be provided at the site by the customer.

Materials and equipment listed in sections A2.4 to A2.9 may be purchased from the GE Service Germany.

#### **A2.2 Materials**

- Foundation including anchor bolts, nuts, and washers
- Earthing (grounding) conductors including terminals and fasteners
- Supports / lattice supports conforming to GE Grid GmbH drawings
- High voltage terminal pads including fasteners
- Gas for filling the breaker
- Squared timbers and boards on which pole columns can rest before installation.

#### **A2.3 Hoisting and Climbing or Lifting Equipment**

- Crane of sufficient lift height and load-carrying capacity
- Slings and lifting tackle of sufficient load-carrying capacity
- Ladders or lifting platforms.

#### **A2.4 Tools, Test Equipment and Auxiliary Equipment**

- Gas-filling device with pressure reducing valve and type Dilo DN8 coupling
- SF<sub>6</sub> leak detector
- Multimeter
- Measuring device for determining operating times
- Measuring device for determining contact resistance
- Assembly tools based on our tool recommendations
- Metal brush with stainless steel bristles.

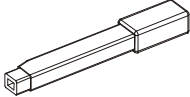
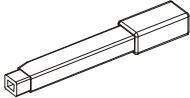
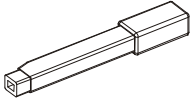
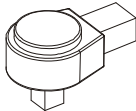
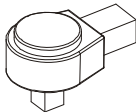
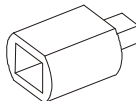

## TOOLS AND AUXILIARY EQUIPMENT

### A2.4.1 Tool Recommendations

Tool	Description	Illustration
T001	Torque wrench (spanner), 8-40Nm; 9x12mm seat; length $\leq$ 390mm	
T002	Torque wrench (spanner), 40-200Nm; 14x18mm seat	
T003	Torque wrench (spanner), 80-400Nm; 14x18mm seat	
T004	Ratchet adapter; can be used for 1/2" torque wrench; 9x12mm seat	
T005	Ratchet adapter; can be used for 1/2" torque wrench; 14x18mm seat	
T006	Drive adapter; for use with 14x18mm heads in connection with 9x12mm torque wrench seat	

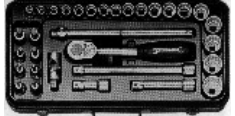
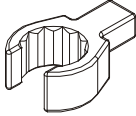
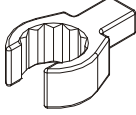
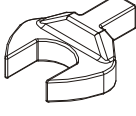
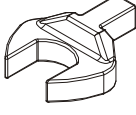
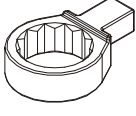

## TOOLS AND AUXILIARY EQUIPMENT

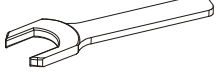
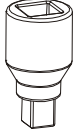
Tool	Description	Illustration
T007	Socket set; ½" seat; consisting of:  - Ratchet - Extensions - Sockets 10-34mm for hexagon bolts or screws 4-14mm for hexagon socket head screws	
T008	Flare nut wrench, 19mm; head for torque wrench (spanner); 9x12mm seat	
T009	Flare nut wrench, 24mm; head for torque wrench (spanner); 9x12mm seat	
T010	Open-end wrench (open-ended spanner), 27mm; head for torque wrench (spanner); 14x18mm seat	
T011	Open-end wrench (open-ended spanner), 36mm; head for torque wrench (spanner); 14x18mm seat	
T012	Box-end wrench (ring spanner), 36mm; head for torque wrench (spanner); 14x18mm seat	
T021	Open-end wrench (open-ended spanner); head for SW27 torque wrench (spanner); 14x18mm seat	
T022	Compact open-end wrench (open-ended spanner), 27mm	
T023	Adapter; 12.5 (½") inside; 10 (⅜") outside	

# TOOLS AND AUXILIARY EQUIPMENT

## Tool Combinations

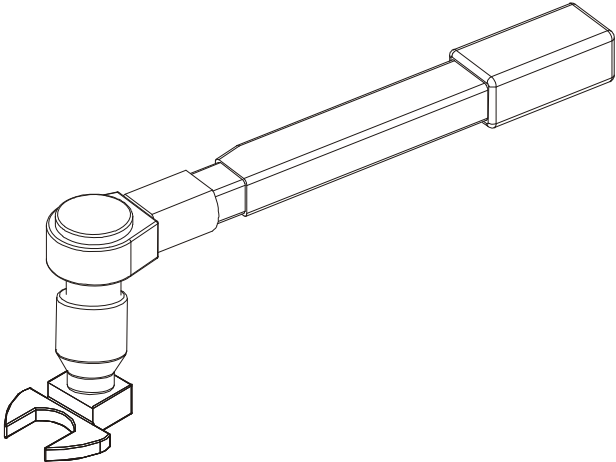
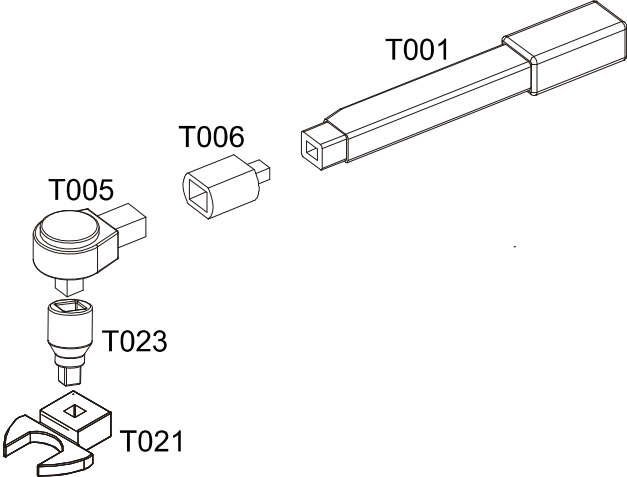
Tool	Illustration	Comment
WK001	<p data-bbox="363 318 619 353">WK001 (combined)</p>  <p data-bbox="363 913 676 949">WK001 (exploded view)</p> 	<p data-bbox="1048 318 1358 389">For tightening gas couplings to specific torque</p>

**A2.5 Greases for Installation, Commissioning and Maintenance**

The following table describes how lubricating greases are to be used and applied. Each application is referred to in the text of the instruction manual by its abbreviation (e.g.: lubricated per L1).

<b>Abbreviation</b>	<b>Name of Lubricating Grease</b>	<b>Function</b>	<b>Application</b>
L1	Molykote BR2plus	Lubrication of threaded connections	Apply a thin coating of grease to the external thread <sup>1)</sup>
L2	Molykote BR2plus	Lubrication of sliding and bearing surfaces	Apply a thin coat of grease to the sliding or bearing surface <sup>1)</sup>
L3	SF 1377 silicone grease	For protecting threaded surfaces from corrosion	Apply a thin coat of grease to the entire area being protected <sup>1)</sup>
L4	SF 1377 silicone grease	Lubrication of threaded connections in gas piping	Apply a thin coating of grease to the external thread <sup>1)</sup>
L5	SF1377 silicone grease plus alcohol	Lubrication of O-rings and O-ring contact surfaces	Clean the O-ring and O-ring mating surfaces with alcohol and apply a thin coat of grease with your fingers. To avoid introducing dirt, do not use brushes or rags <sup>1)</sup>
L6	Molykote PG54	Lubricating electrical contact surfaces in the pole column	Apply a thin coat of grease to the entire contact surfaces
L7	Molykote PG54	Lubricating sliding and bearing surfaces in the pole column	Apply a thin coat of grease to the contact surfaces

<sup>1)</sup> The amounts required for installation and commissioning are supplied by the manufacturer and are included in the breaker shipment.

## TOOLS AND AUXILIARY EQUIPMENT



### A2.6 Locking Adhesives for Installation, Commissioning and Maintenance

The following table describes how locking adhesives are to be used and applied. Each application is referred in the text of the instruction manual by its abbreviation (e.g.: locked per S1).

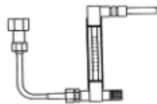

Abbreviation	Name of Locking Adhesive	Function	Application
S1	Loctite 243	Medium strength threadlocker	Apply a light coating of locking adhesive to the first few threads only. The cure time is 30 minutes at room temperature. Low temperatures require a longer cure time <sup>1)</sup>

<sup>1)</sup> The amounts required for installation and commissioning are supplied by the manufacturer and are included in the breaker shipment.

### A2.7 Measuring Devices for Checking Gas Quality

Tool	Description	Illustration
T200	Dew point hygrometer	
T201	SF <sub>6</sub> analyzer, type AW	
T202	Acidity detector tube (10 each) For use with T201	
T203	SF <sub>6</sub> volume percentage measuring device	

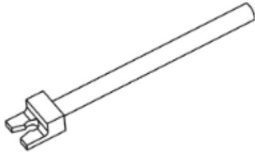
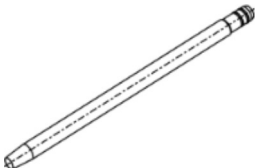
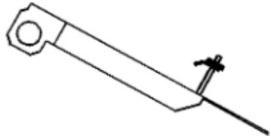
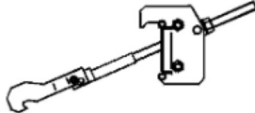
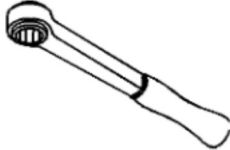
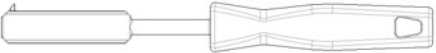
A2.8 Tools for Reconditioning

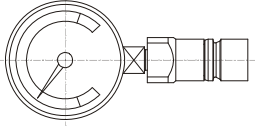
Tool	Description	Illustration
T101	Assembly tool for cotter pins	
T102	Guide tool for interrupter unit	
T103	Blocking device: device for blocking the closing latch	
T104	Slow operation device: device for slow closing and opening operations	
T105	Ratchet box wrench (ring spanner) for M16: standard tool for operating the slow operation device	
T114	Assembly tool for aplint pin	
T115	Assembly tool for coupling pin	
T116	SF <sub>6</sub> -Shipping pressure indicator	

## TOOLS AND AUXILIARY EQUIPMENT

---

Tool	Description	Illustration
T122	Pliers for installing circlips DIN 471; shaft diameter: 10 - 25 mm	

### A2.9 Auxiliary Materials and Supplies

Description	Quantity
Molykote BR 2 plus grease	0.20kg 0.40kg 0.80kg
SF 1377 silicone grease	0.25kg 0.50kg
Molykote PG 54 grease	1.00kg
Locking adhesive Loctite 243 (blue)	10cm <sup>3</sup> 250cm <sup>3</sup>
Alcohol for cleaning	5l
Scotch brand nonwoven material	10mx100mm

**A3 Replacement Parts and Accessories**

Replacement parts and accessories for circuit breakers can be purchased from the GE Service Germany.

The replacement parts have been broken down into several recommended groups based on many years of experience.

**Replacement Parts List "R" = Always Recommended**

Description
Coil E/A FK3*
Contactors (K11, K14, K17, K24)*
Auxiliary switch block (top K14)
Contactors for synchronized operation (F3) (K40)*
* Different variants or operating voltages; specify serial number of device

**Replacement Parts List "U" = Useful for 5 Devices or More**

Description
Motor*
Cartridge heater*
Auxiliary switch assembly
Motor protection switch*
Time-delay relay 0.05s-60h 24-240V AC/DC
Miniature circuit breaker (F10)
Undervoltage release FK3*
* Different variants or operating voltages; specify serial number of device

**Replacement Parts List "P" = Keep on hand if there are a large number of devices or to shorten repair time**

Description
Replacement parts for interrupter chamber*
Drier bag
Gasket set**
Remote-local switch with or without open position**
* Different variants or operating voltages; specify serial number of device
**Specify serial number of device

## REPLACEMENT PARTS AND ACCESSORIES

### Other Replacement Parts and Accessories

Description
Gas cylinder, 5kg
Gas cylinder, 10kg
Gas cylinder, 15kg
Gas cylinder, 20kg
Gas cylinder, 40kg
SF <sub>6</sub> gas refill set
Leak detector HI300
Density monitor*
Socket outlet with earthing (grounding) contact
Lighting attachment, door contact**
Terminal UK 5 N 751
Ground (earth) terminal UK5N/USLKG10
Button temperature controller
Manual crank handle FK3
Saeka cleaning paste
Loctite 243 blue 250 ml
Molykote BR 2 grease, 400 g
Box of assorted circuit breaker parts & accessories
* Different variants or operating voltages; specify serial number of device
**Specify serial number of device

### A3.1 Servicing Equipment

Description
Service device with vacuum pump and cryoliquefier
Gas-filling cart with vacuum pump
Dew point hygrometer
SF <sub>6</sub> analyzer, type AW
- plus: Acidity detector tube (10 each)
SF <sub>6</sub> volume percentage measuring device
Actas measuring computer for operating time/displacement/ power consumption, Micro-Ohmmeter 600A



### A3.2 Replacement of Arcing Contacts

The following replacement parts are required for replacing arcing contacts. The number of replacement parts refers to one pole column.

Description	Quantity
Interrupter unit	1x
Flanged coupling pin, 6x24	4x
Cotter pin, 8x1.2	4x
Guide strip 3x5x398	1x
Guide strip 3x5x380	1x
Arcing contact pin	1x
Guide strip 3x5x146	2x
Formed gasket 271	2x
Socket head cap screw M8x12 A2-70	1x
Coupling pin	1x
Socket head cap screw M8x20 A-70	1x
Formed gasket 221	1x
O-ring 62.87x5.33	1x
Filter bag	1x

### A3.3 Replacement Parts for Installation Work on Post Insulator and Crankcase

The following replacement parts are required for such operations. The number of replacement parts refers to one pole column.

Description	Quantity
Formed gasket 221	2x
Coupling pin	1x
O-ring 34.52 x 3.53	1x
O-ring 62.87 x 5.33	2x
O-ring 38.82 x 5.33	2x
O-ring 12.37 x 2.62	1x
Filter bag	



### A4 Handling Used Sulfur Hexafluoride

Sulfur hexafluoride (SF<sub>6</sub>) can become contaminated when used in electrical equipment. Contamination can result from leaks, incomplete evacuation, partial discharges, decomposition caused by electric arcs and mechanical erosion. Used SF<sub>6</sub> is a valuable recyclable material that must be reconditioned and re-used.

The guidelines for analyzing and reconditioning sulfur hexafluoride after removal from electrical equipment and the specifications for its re-use are defined in standard IEC 60480.

Standard IEC 62271-4 describes the use and handling of SF<sub>6</sub> in high voltage switchgear.

Before used SF<sub>6</sub> is recycled, it must be analyzed and generally reconditioned in order to meet standard specifications. The reconditioning process removes the impurities. Reconditioning is handled by the SF<sub>6</sub> manufacturer. If the SF<sub>6</sub> is only slightly contaminated, it can also be treated on site using appropriate maintenance equipment (instructions are given in standard IEC 60480).

<b>How do you ensure that used SF<sub>6</sub> will be handled correctly?</b>	By complying with the procedures defined in standards IEC 60480 and IEC 62271-4.
<b>What requirements must the operator meet?</b>	The operator must ensure that the procedures defined in standards IEC 60480 and IEC 62271-4 are followed and that the personnel assigned to carry out these procedures are qualified to handle used SF <sub>6</sub> . Within the European Union, the assigned personnel must be qualified in accordance with EU Regulation 842/2006.
<b>How is used SF<sub>6</sub> handled?</b>	Used SF <sub>6</sub> is analyzed, reconditioned if necessary, and re-used. The relevant guidelines and specifications are defined in standard IEC 60480.



**A5 Technical Description**
**A5.1 Technical Data: Circuit Breaker Type GL 310-GL 311**

Type		GL 310 F1/4031	GL 310 F1/4040	GL 311 F1/4031	GL 311 F1/4040
Rated voltage	kV	100	100	123	123
Rated normal current	A	3150	4000	3150	4000
Rated frequency	Hz	50 / 60*	50 / 60*	50 / 60*	50 / 60*
Rated power-frequency withstand voltage 50 Hz, 1 min					
- To ground	kV	185	185	230	230
- Across open switching device	kV	185	185	230	230
Rated lightning impulse withstand voltage					
- To ground	kV	450	450	550	550
- Across open switching device	kV	450	450	550	550
Rated switching impulse withstand voltage (Vn > 245 kV)					
- To ground	kV	not applicable			
- Across open switching device	kV	not applicable			
Rated short-circuit breaking current					
- R.m.s. value of the a.c. component of current	kA	40	40	40	40
- Percentage of d.c. component	%	45	45	45	45
Minimum opening time	ms	26	26	26	26
First-pole-to-clear factor		1,3 / 1,5	1,3 / 1,5	1,3 / 1,5	1,3 / 1,5
Transient recovery voltage					
- Peak value	kV	171	171	211	211
- Rate of rise	kV/ μs	2,0	2,0	2,0	2,0
Short-line fault					
- Surge impedance	Ω	450	450	450	450
- Peak factor		1,6	1,6	1,6	1,6
Rated short-circuit making current	kA	104	104	104	104
Rated out-of-phase breaking current	kA	10	10	10	10
Rated duration of short circuit	s	3	3	3	3
Rated operating sequence		O-0,3s-CO-3min-CO bzw. CO-15s-CO			
Rated line-charging breaking current	A	20	20	31,5	31,5
Rated cable-charging breaking current	A	125	125	140	140
SF <sub>6</sub> weight per breaker -30°C / -40°C (porcelain insulator)	kg	8,3 / 7,8	9,8 / 7,2	8,3 / 7,8	9,8 / 7,2
SF <sub>6</sub> weight per breaker -30°C / -40°C (composite insulator)	kg	13,0 / 9,6	--	13,0 / 9,6	--
*60 Hz only for -30°C					

## TECHNICAL DESCRIPTION

### A5.2 Technical Data: Circuit Breaker Type GL 312 - GL 313

Type		GL 312 F1/4031	GL 312 F1/4040	GL 313 F1/4031
Rated voltage	kV	145	145	170
Rated normal current	A	3150	4000	3150
Bemessungs-Frequenz	Hz	50 / 60*	50 / 60*	50 / 60*
Rated power-frequency withstand voltage 50 Hz, 1 min				
- To ground	kV	275	275	325
- Across open switching device	kV	275	275	325
Rated lightning impulse withstand voltage				
- To ground	kV	650	650	750
- Across open switching device	kV	650	650	750
Rated switching impulse withstand voltage (Vn > 245 kV)				
- To ground	kV	not applicable		
- Across open switching device	kV	not applicable		
Rated short-circuit breaking current				
- R.m.s. value of the a.c. component of current	kA	40	40	40
- Percentage of d.c. component	%	45	45	45
Minimum opening time	ms	26	26	28
First-pole-to-clear factor		1,3 / 1,5	1,3 / 1,5	1,3 / 1,5
Transient recovery voltage				
- Peak value	kV	249	249	291
- Rate of rise	kV/ μs	2,0	2,0	2,0
Short-line fault				
- Surge impedance	Ω	450	450	450
- Peak factor		1,6	1,6	1,6
Rated short-circuit making current	kA	104	104	104
Rated out-of-phase breaking current	kA	10	10	10
Rated duration of short circuit	s	3	3	3
Rated operating sequence		O-0,3s-CO-3min-CO bzw. CO-15s-CO		
Rated line-charging breaking current	A	50	50	63
Rated cable-charging breaking current	A	160	160	160
SF <sub>6</sub> weight per breaker -30°C / -40°C (porcelain insulator)	kg	8,3 / 7,8	9,8 / 7,2	11,9 / 8,8
SF <sub>6</sub> weight per breaker -30°C / -40°C (composite insulator)	kg	13,0 / 9,6	--	14,3 / 10,6
*60 Hz only for -30°C				

**A5.3 Technical Data: Spring Operating Mechanism**

Type		FK 3-1
Motor for charging the closing spring		
Rated voltage (preferred values)		
- Direct voltage	V	60/110/125/220/250 *)
- Alternating voltage	V	120/230 *)
Allowable rated voltage deviation		85 to 110 % Vn
Power consumption	W	≤ 1000
Closing spring charging time	s	≤ 15
Shunt releases, closing and opening:		
Rated supply voltage (preferred values only with direct voltage)	V	60/110/125/220/250 *)
Allowable rated supply voltage deviation		
- Shunt closing release		85 to 110 % Vn
- Shunt opening release		70 to 110 % Vn
Power consumption of releases		
- Shunt closing release	W	340
- Shunt opening release	W	340
Minimum pulse duration	ms	10
Auxiliary circuits:		
Rated continuous load current	A	10
Auxiliary contact tripping capability		
- At 230 V alternating voltage	A	10
- At 220 V direct voltage in an inductive circuit with a time constant of L/R = 20 ms	A	2
Anti-condensation heating unit:		
Rated voltage (preferred values)	V	120 or 230 *)
Power consumption	W	80
*) Specify when ordering		





### **A6 Slow Operation for Maintenance Purposes**

#### **Introduction**

These instructions describe the following manual operations:

- Executing a slow closing operation
- Executing a slow opening operation

Manual operations in accordance with these instructions are not necessary during installation work and during normal breaker operation.

Slow closing or opening operations can be used for setting, adjusting and checking the circuit breaker, if necessary.

After improper manipulations or when there are problems with the breaker, it may be necessary to close or open the breaker slowly and discharge the closing spring manually in order to eliminate a problem or fault.

#### **Safety Precautions**

Stored-energy spring mechanisms have been designed according to the state of the art and are safe and reliable. Nonetheless, these devices can be hazardous if operated improperly.

The circuit breaker operator must therefore ensure that all personnel working on the equipment will meet the following requirements:

- Technical knowledge regarding local and national safety and accident prevention regulations, especially for high voltage systems and devices
- Knowledge of and compliance with the contents of this document
- Professional training in the area of circuit breakers and stored-energy spring mechanisms
- Compliance with the safety instructions displayed on the device
- Agreement to report immediately any changes that may compromise safety

#### **Requirements for Executing Manual Operations**

- The circuit breaker is in the open position.
- The circuit breaker is grounded (earthed) at both ends.
- The control voltage is turned off.

## **SLOW OPERATION FOR MAINTENANCE PURPOSES**

---

### **Safety in General**

- Any manipulations of the equipment that do not conform to instructions may endanger both the individuals performing the manipulations and the spring mechanism.
- If manipulations are performed on the spring mechanism that are not in compliance with FK3-.. instructions, then the individual performing the manipulations is at risk of death or injury. The spring mechanism can also be damaged in the process



**Perform only manipulations that comply with these instructions.**

---

### **Personal Safety When Performing Manipulations on the Operating Mechanism**

- After the control voltage is turned off, the closing spring is charged. Although the control voltage is interrupted, accidental operations are possible when performing manipulations on the operating mechanism.
- Touching moving parts poses a risk of injury.



**After control voltage has been interrupted, discharge the springs by executing opening, closing and opening operations using the manual releases.**

- 
- Spring mechanisms with undervoltage releases open immediately as soon as the control voltage is interrupted.
  - This can lead to injury when manipulations are being performed on the spring mechanism.



**Prevent unintentional or accidental opening operations by locking the undervoltage releases.**

- 
- If the motor voltage is switched on, the motor will immediately begin to charge the closing spring.
  - Touching moving and/or spring-charged parts poses a risk of injury.



**Keep parts of the body away from any moving or spring-charged parts when turning on the control voltage.**

---

## **SLOW OPERATION FOR MAINTENANCE PURPOSES**

---

### **Product Safety**

- If the spring mechanism is operated without the circuit breaker, the total energy stored within the spring mechanism will be converted.
- The mechanism can be severely damaged as a result.



**Only operate the spring mechanism when the circuit breaker is connected.**

- 
- If the gas pressure of the circuit breaker is below the minimum value for mechanical operation (visible on the warning plate or label inside the spring mechanism), then an unacceptably high level of energy is converted within the spring mechanism.
  - This can damage both circuit breaker and spring mechanism.

---



**CAUTION**

**Operate the spring mechanism only with a circuit breaker in which the gas pressure is above the minimum value for mechanical operation.**

- 
- Dust inside the spring mechanism can have an adverse effect on operation of moving parts such as latches, rollers, shafts and on the response of electrical devices.
  - This can lead to malfunctions and result in damage to the spring mechanism.

---



**CAUTION**

**Always keep the inside of the spring mechanism free of dust. Always close the cabinet door properly.**

- 
- The use of cleaning agents, rust-preventing grease or sprays may result in heavy gum formation (gumming).
  - This can have a negative effect on the operation of the spring mechanism.
  - Moisture inside the spring mechanism leads to water condensation and subsequent corrosion of steel parts.
  - This may lead to malfunctions and result in damage to the spring mechanism.

---



**CAUTION**

**The heating unit (anticondensation heater) must always be in operation, regardless of circuit breaker location.**

---

## SLOW OPERATION FOR MAINTENANCE PURPOSES

### Preparing the Spring Mechanism for Manual Operations

#### Preparing the Cabinet

If	Then
Cabinet is mounted horizontally; mounted on rear panel	<ul style="list-style-type: none"><li>• Remove the side panels (1)</li><li>• Remove the side panel lock nuts (2)</li><li>• Swing the side panel (1) out and down</li></ul>

Horizontal mounting configuration shown

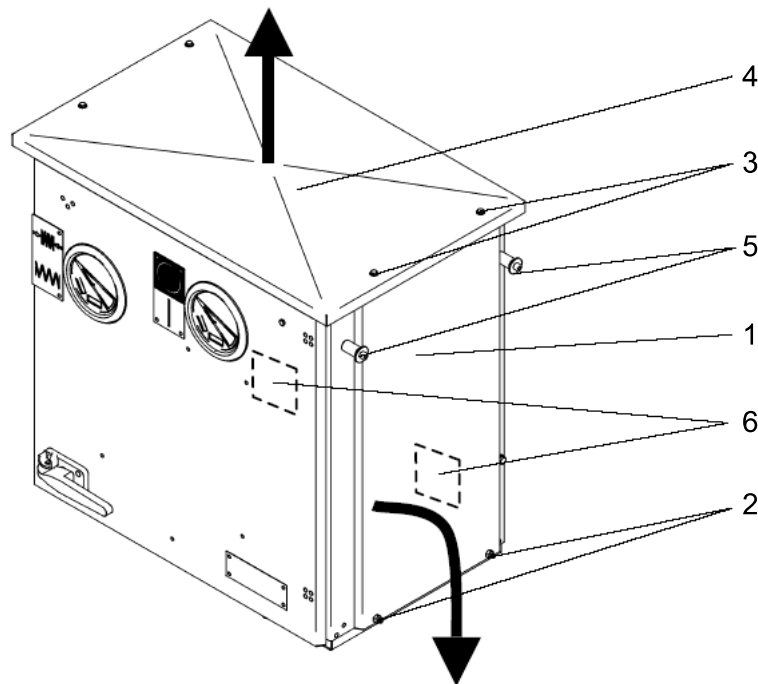

1 Side panel	4 Roof
2 Side panel lock nut	5 Suspension pin
3 Roof mounting screw	6 Cover plate

#### Locking the Manual Releases

- The manual releases may be actuated unintentionally when manipulations are being performed on the spring mechanism.
- Manipulating the spring mechanism without locking the manual releases poses risk of injury.



**Prevent inadvertent manual actuation of the spring mechanism by locking manual trip devices or releases.**

## SLOW OPERATION FOR MAINTENANCE PURPOSES

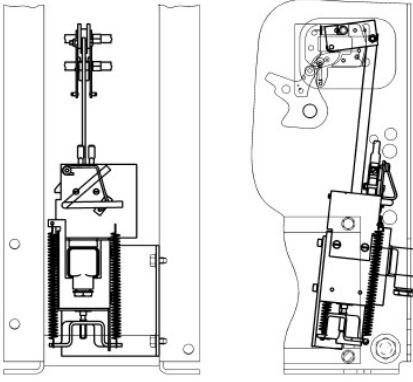
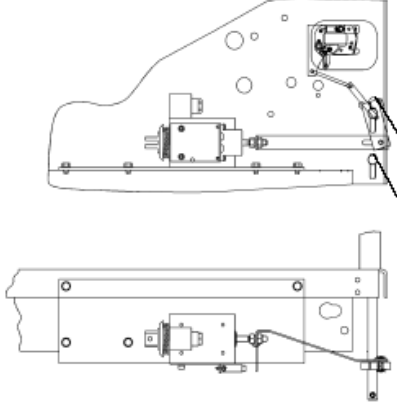
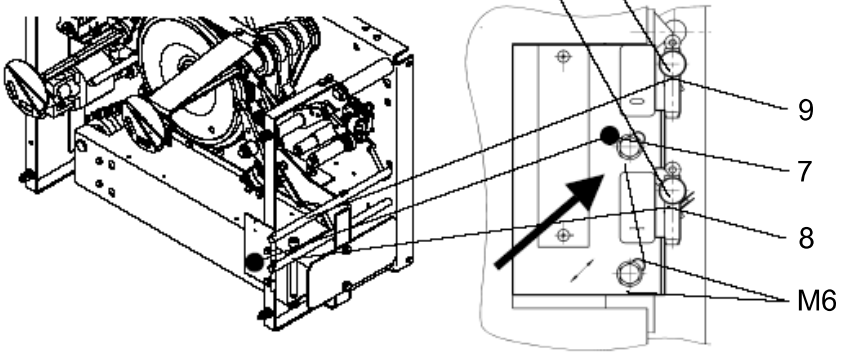
<b>If</b>	<b>Then</b>
<p>Spring mechanism has no under-voltage release</p>	<p>Manual releases are normally locked.</p> <p>If this is not the case:</p> <ul style="list-style-type: none"> <li>• Loosen the M6 screws.</li> <li>• Slide manual release locking device (7) in the direction of the arrow until manual releases are locked.</li> <li>• Retighten the M6 screws.</li> </ul>
<p>Spring mechanism has under-voltage release and integrated locking device</p> 	<p>Manual releases are normally locked.</p> <p>If this is not the case:</p> <ul style="list-style-type: none"> <li>• Loosen the M6 screws.</li> <li>• Slide manual release locking device (7) in the direction of the arrow until manual releases are locked.</li> <li>• Retighten the M6 screws.</li> </ul>
<p>Spring mechanism has under-voltage release but no locking device</p> 	<p>The manual release locking device (7) is normally not installed in this model.</p> <ul style="list-style-type: none"> <li>• Slide manual release locking device (7) in the direction of the arrow until manual releases are locked.</li> <li>• Tighten the M6 screws.</li> </ul>
<p>Manual release locking device</p> 	

7 Manual release locking device	9 Manual opening release
8 Manual closing release	

## SLOW OPERATION FOR MAINTENANCE PURPOSES

### Locking the Undervoltage Releases

- If the spring mechanism is equipped with undervoltage releases and if slow closing or opening operations are necessary, then the undervoltage release must be locked.

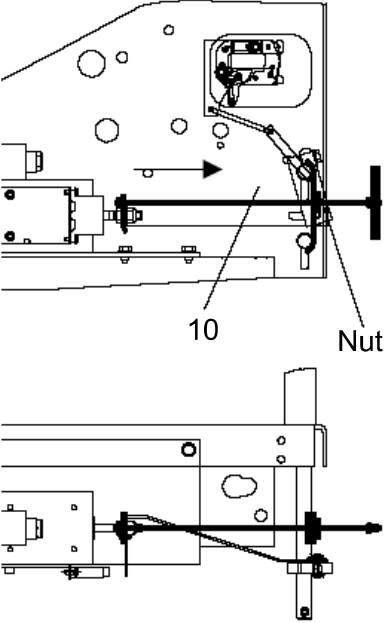
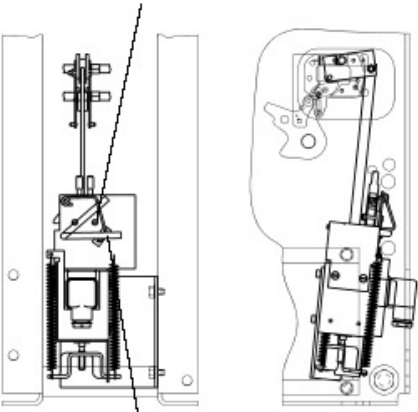
If	Then
<p>Undervoltage release has no locking device</p>  <p>10 Locking device for undervoltage release</p>	<p>Insert hook of locking device (10) and pull out solenoid until it hits the stop;</p> <ul style="list-style-type: none"> <li>• then hand-tighten the nut slightly.</li> </ul>
<p>Undervoltage release has integrated locking device</p> <p>Locking lever in operation position</p>  <p>Locking lever in locking position</p>	<ul style="list-style-type: none"> <li>• Turn the locking lever from operation position to locking position</li> </ul>

## SLOW OPERATION FOR MAINTENANCE PURPOSES

### Locking the Closing Latch if the Closing Spring is Charged

- The closing latch may be actuated unintentionally when manipulations are being performed on the spring mechanism.
- Performing manipulations on the spring mechanism when the closing spring is charged and the closing latch is not locked poses a risk of injury.



Prevent inadvertent manual actuation of the spring mechanism by locking the closing latch.

- Insert the locking device (11) for the closing latch (12) and fasten it to the shaft of the manual opening release (9).

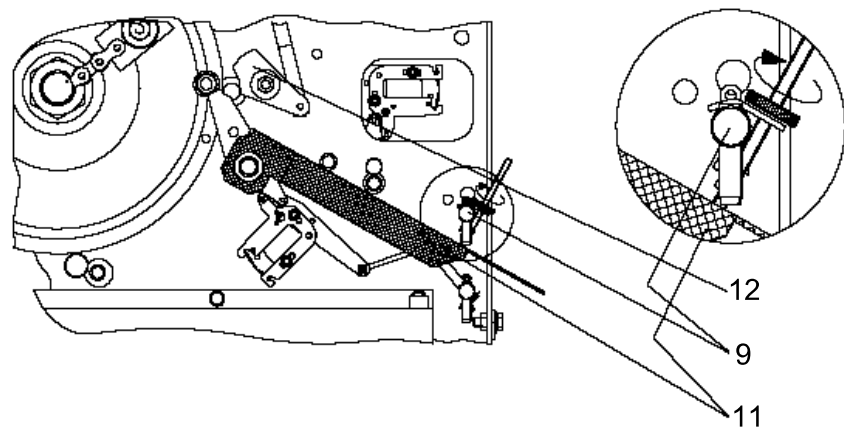

9 Manual opening release	11 Locking device for the closing latch
12 Closing latch	

### Removing the Safety Plate

- Remove the safety plate (13).

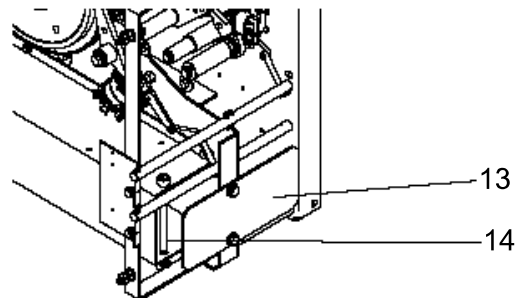

13 Safety plate	14 Self-locking bolt
-----------------	----------------------

## SLOW OPERATION FOR MAINTENANCE PURPOSES

### Executing a Slow Closing Operation

The spring mechanism is prepared for manual operations.

### Checking the Operating State of the Circuit Breaker and the Spring Mechanism

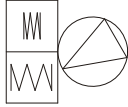
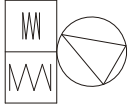
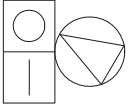
Position of Position Indicator		
		
Spring position indicator shows closing spring is uncharged or charged		Breaker position indicator is in open position

### Tools Required

7 Locking plate for manual <sup>1)</sup>
10 Locking device for undervoltage release <sup>1)</sup>
11 Locking device for the closing latch
15 Slow operation device
16 Closing spring release device

<sup>1)</sup> Only required for spring mechanisms equipped with an undervoltage release and no integrated locking device.



## SLOW OPERATION FOR MAINTENANCE PURPOSES

### Installing the Slow Operation Device

- Place the support plate (17) of the slow operation device (15) on the upper right spacer sleeve (18) and prop the device against the mechanism housing.
- Attach the hook (19) of the slow operation device to the pin (20) of the support latch (21).

### Closing Manually

- Turn the hexagon nut (22) clockwise until the support latch (21) of the roller follower (23) engages with the opening latch (24) by audibly snapping into place.
- During the slow closing operation, the opening springs in the pole columns and the mechanism are charged simultaneously. Overcharging is prevented by the stop sleeve (25).
- The breaker position indicator is now in the closed position.

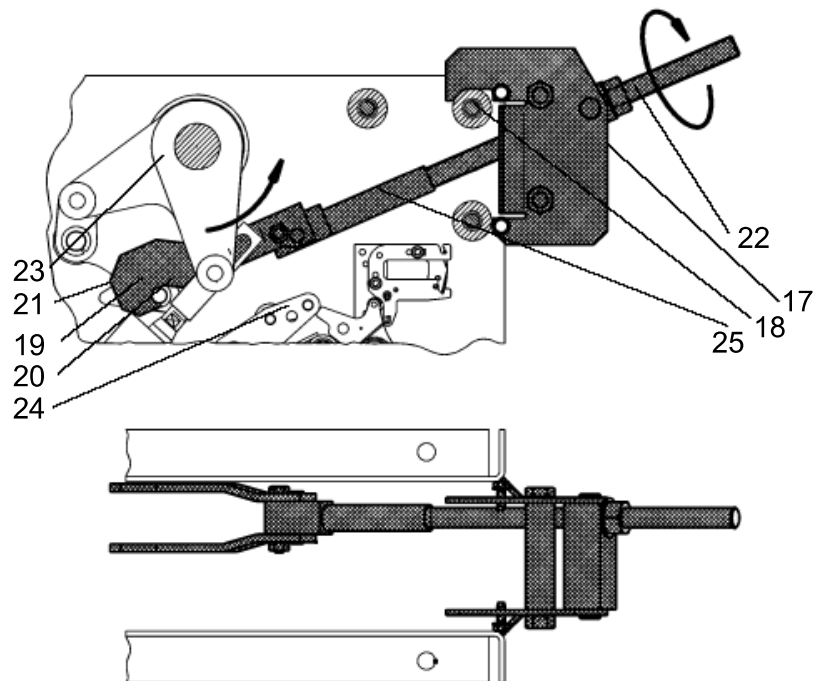

17 Support plate	22 Hexagon nut
18 Spacer sleeve	23 Roller follower
19 Hook	24 Opening latch
20 Pin	25 Stop sleeve
21 Support latch	

## SLOW OPERATION FOR MAINTENANCE PURPOSES

### Operating State after Slow Closing

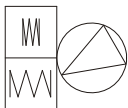
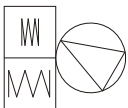
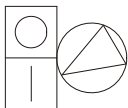
Position of Position Indicator		
		
Spring position indicator shows closing spring is uncharged or charged		Breaker position indicator is in closed position, opening spring is charged

### Removing the Slow Operation Device

- Turn the hexagon nut (22) counterclockwise until enough pressure is removed from the hook (19) that the slow operation device (15) can be removed.

### Executing a Slow Opening Operation

The spring mechanism is prepared for manual operations.

### Checking the Operating State of the Circuit Breaker and the Spring Mechanism

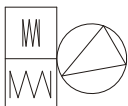
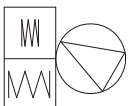
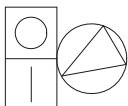
Position of Position Indicator		
		
Spring position indicator shows closing spring is uncharged or charged		Breaker position indicator is in closed position, opening spring is charged

### Tools Required

7 Locking plate for manual release <sup>1)</sup>
10 Locking device for undervoltage release <sup>1)</sup>
11 Locking device for the closing latch
15 Slow operation device
16 Closing spring release device

- <sup>1)</sup> Only required for spring mechanisms equipped with an undervoltage release and no integrated locking device.

## SLOW OPERATION FOR MAINTENANCE PURPOSES

### **Installing the Slow Operation Device**

- Place the support plate (17) of the slow operation device (15) on the upper right spacer sleeve (18) and prop the device against the mechanism housing.
- Attach the hook (19) of the slow operation device to the pin (20) of the support latch (24).

### **Removing Pressure from the Opening Latch**

- Turn the hexagon nut (22) clockwise using the tool until the torque increases, i.e., until pressure is removed from the opening latch (24).

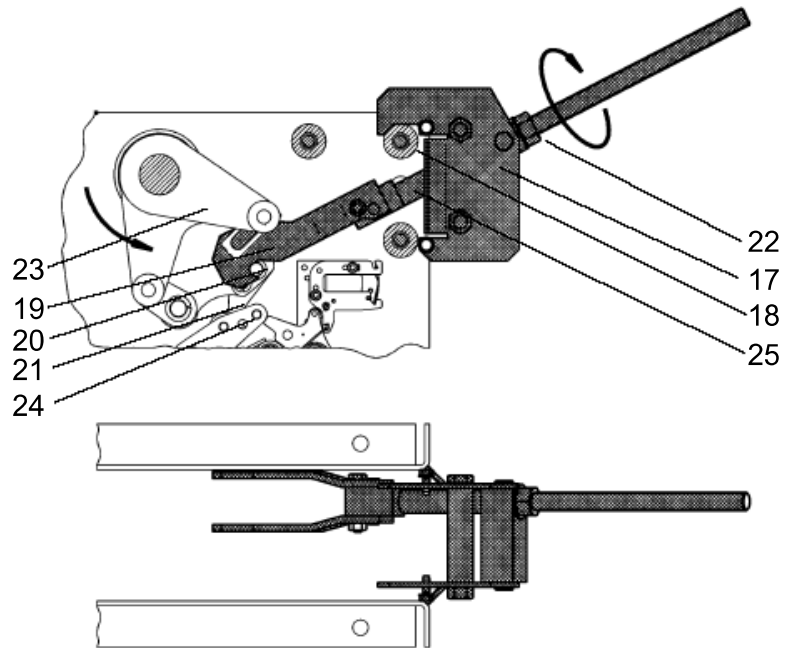

17 Support plate	22 Hexagon nut
18 Spacer sleeve	23 Roller follower
19 Hook	24 Opening latch
20 Pin	25 Stop sleeve
21 Support latch	

## SLOW OPERATION FOR MAINTENANCE PURPOSES

### Loosening the Manual Release Locking Device

- Loosen the M6 screws.
- Slide the manual release locking device (7) in the direction of the arrow.
- Tighten the M6 screws.

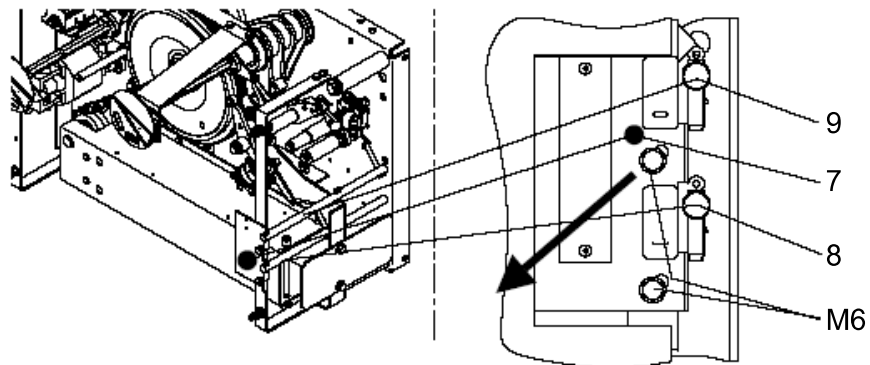

7 Manual closing release	9 Manual release locking device
8 Manual opening release	

## SLOW OPERATION FOR MAINTENANCE PURPOSES

### Opening Manually

- Release the opening latch (24) using the manual opening release (9).
- At the same time, turn the nut (22) counterclockwise until the support latch (21) of the roller follower (23) has passed the opening latch (24).
- Continue turning the nut (22) counterclockwise until the pressure is removed from the hook (19).
- At the end of this operation, the opening springs in the pole columns and the mechanism are discharged and the breaker position indicator indicates that the circuit breaker is open.

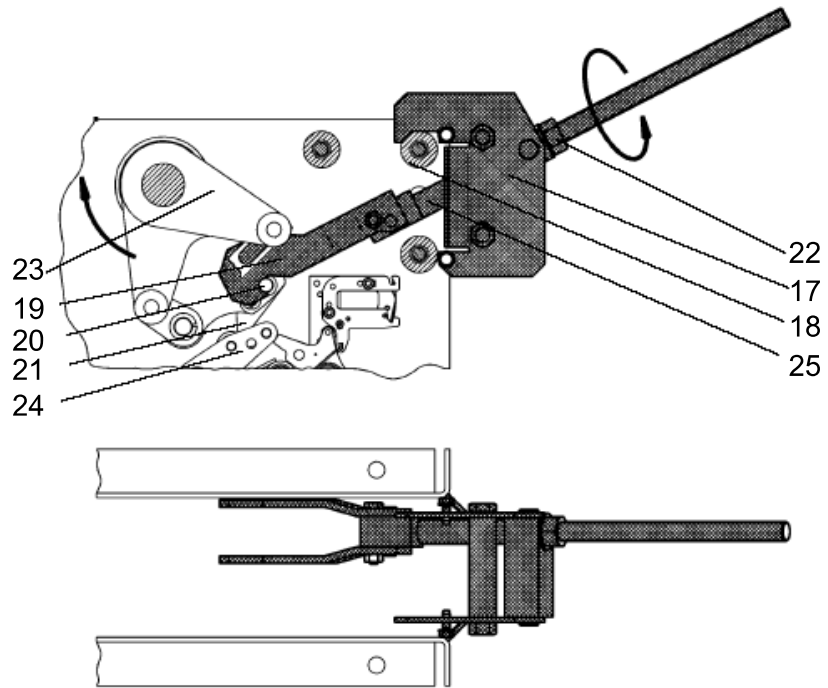

17 Support plate	22 Hexagon nut
18 Spacer sleeve	23 Roller follower
19 Hook	24 Opening latch
20 Pin	25 Stop sleeve
21 Support latch	

## SLOW OPERATION FOR MAINTENANCE PURPOSES

### Removing the Slow Operation Device

- Turn the hexagon nut (22) counterclockwise until enough pressure is removed from the hook (19) that the slow operation device (15) can be removed.

### Relocking the Manual Releases

- Loosen the M6 screws.
- Slide the manual release locking device (7) in the direction of the arrow until manual releases (8) and (9) are locked.
- Retighten the M6 screws.

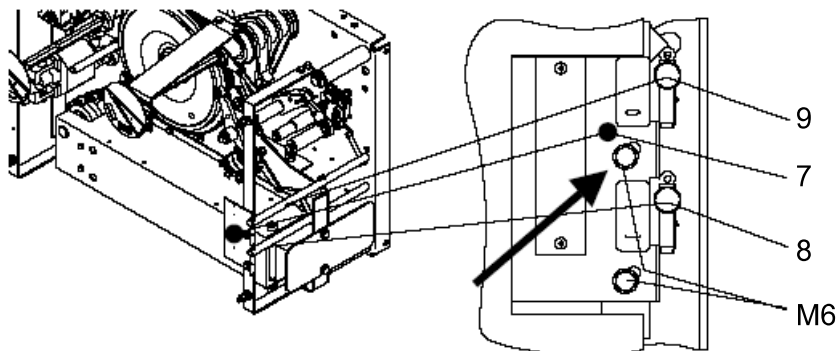

7 Manual closing release	9 Manual release locking device
8 Manual opening release	

### Operating State of the Spring Mechanism after the Slow Opening Operation

Position of Position Indicator		
Spring position indicator shows closing spring is uncharged or charged		Breaker position indicator is in open position, opening spring is discharged

